

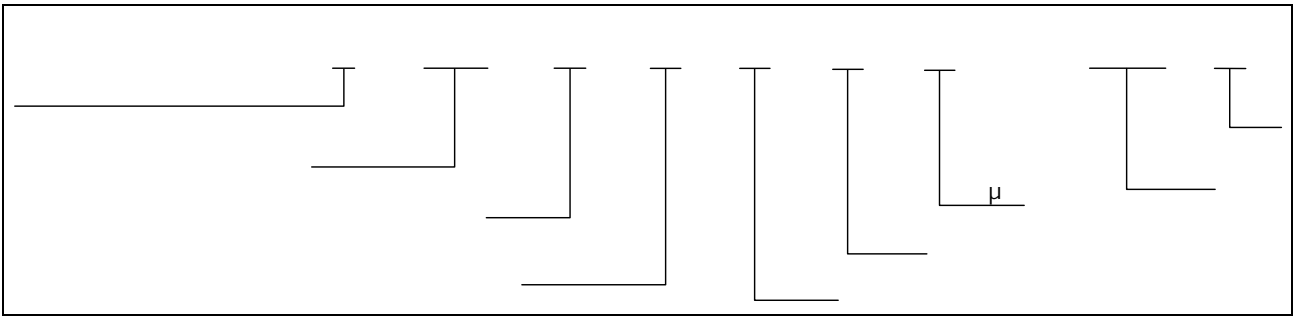

Parameter		Symbol	Condition	Min.	Typ.	Max.	Unit



DIP	50 Units/Tube	40 Tubes/Inner box	5 Inner box/Outer box =10k Units
SMD	1200 Units/Reel	2 Reels/Inner box	5 Inner box/Outer box =12k Units

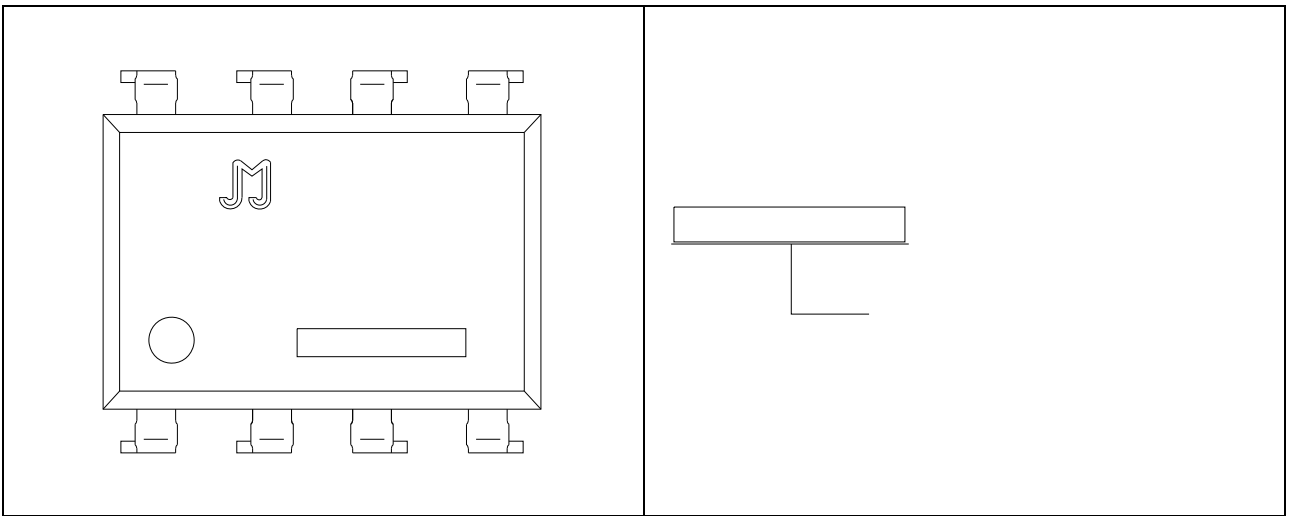

FIG.1:

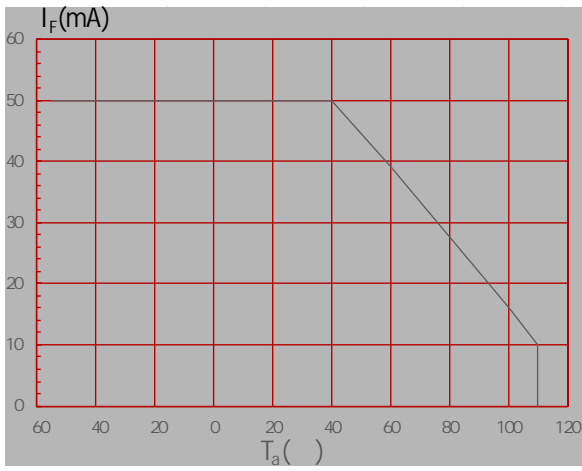

FIG.2:

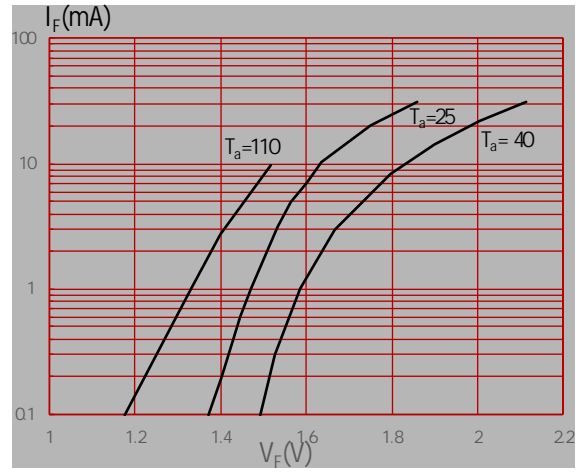

FIG.3:

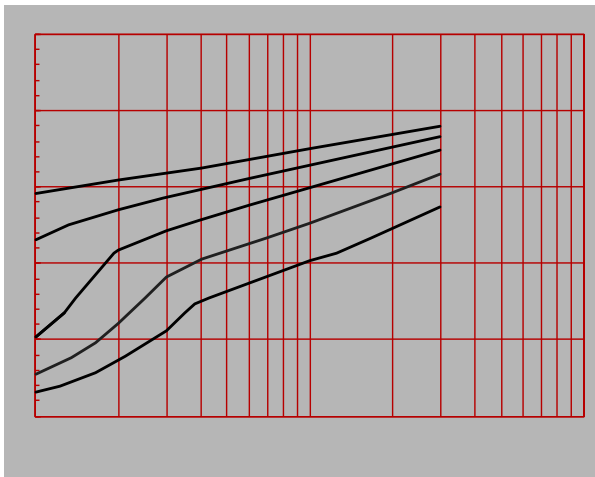
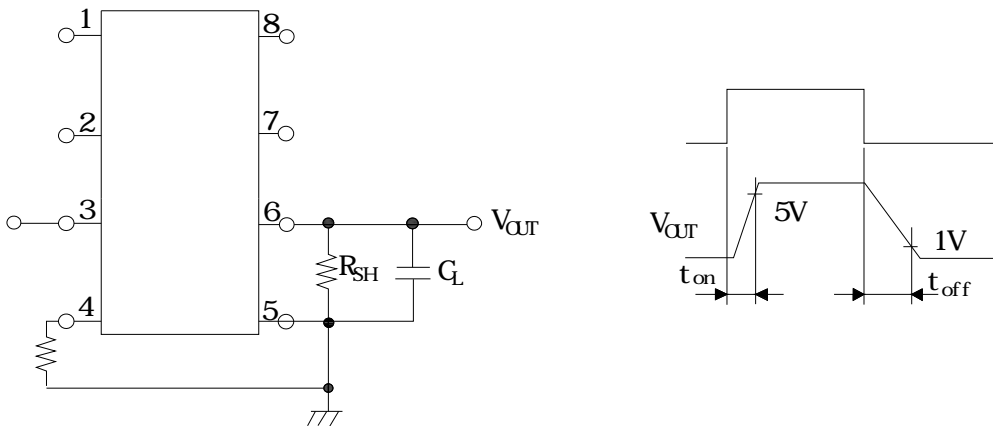
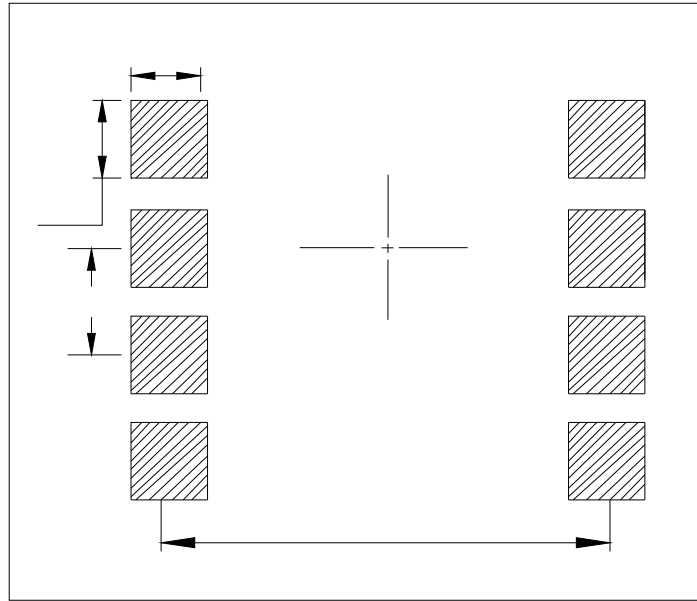

FIG.4:

FIG.7: Response Time Test Circuit, Waveform







**Standard DIP**

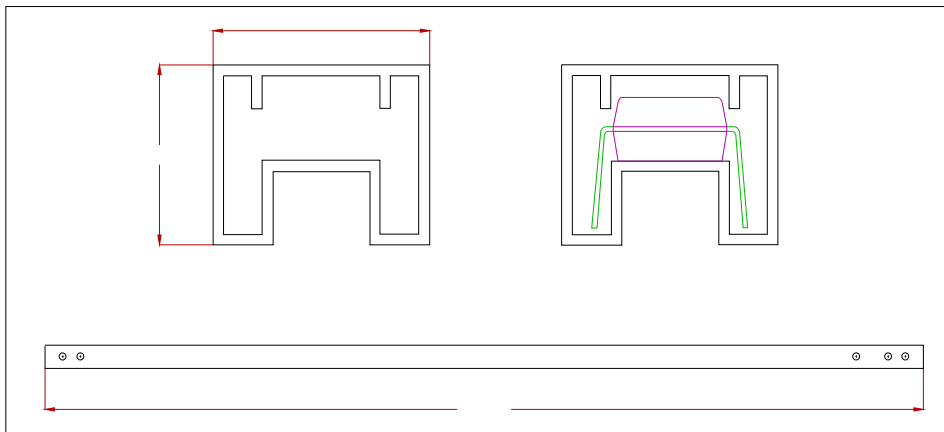

Option S

