

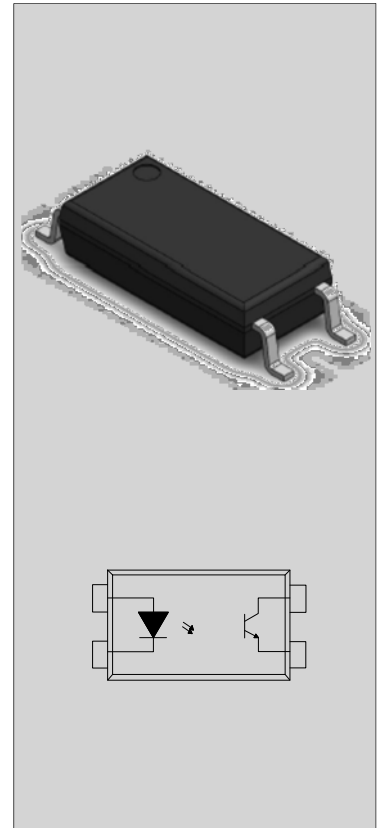

**DESCRIPTION:**

**MAIN FEATURES**



**ABSOLUTE MAXIMUM RATINGS**





NOTE1

NOTE2

### ELECTRICAL CHARACTERISTICS

NOTE1



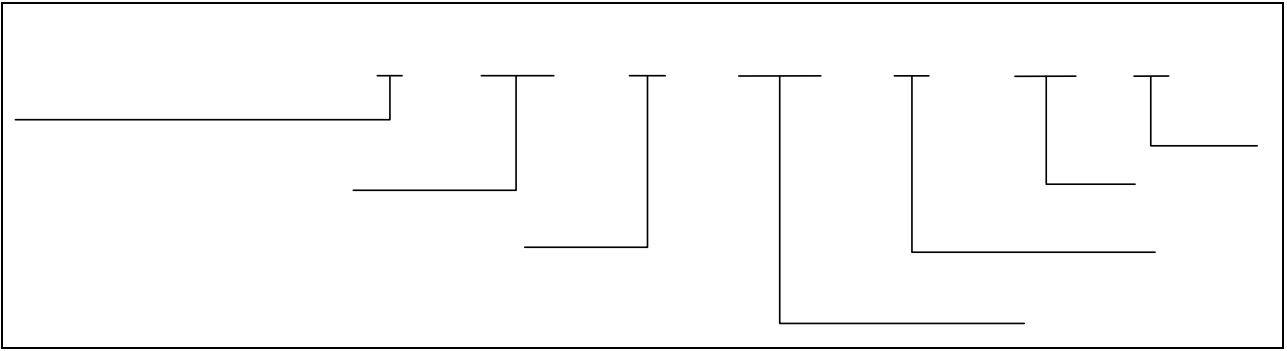

## ORDERING INFORMATION

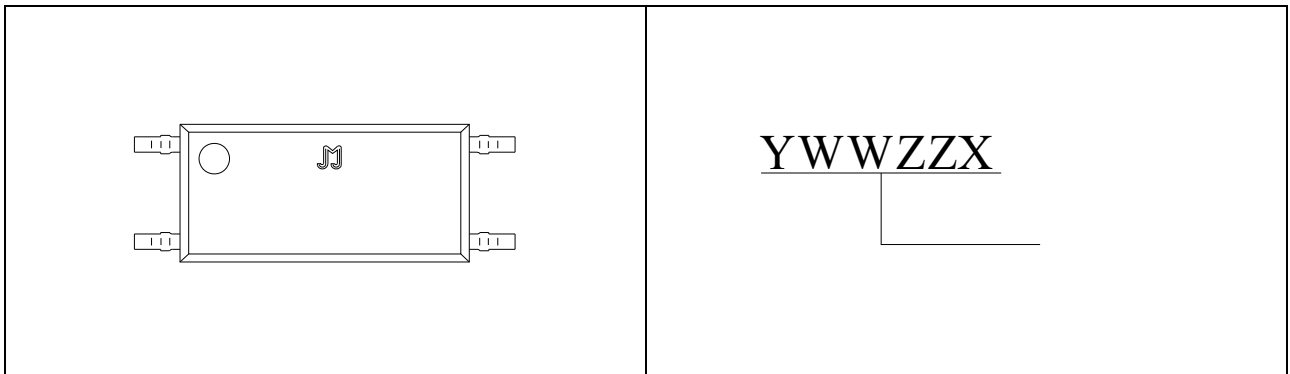

Packing Quantity	
Option	Quantity

## MARKING





# Characteristics Curves

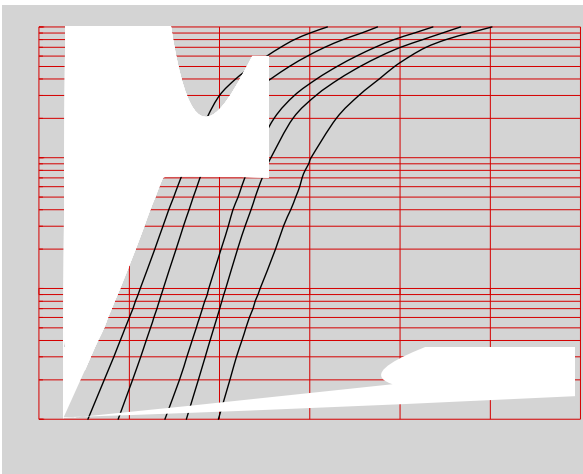
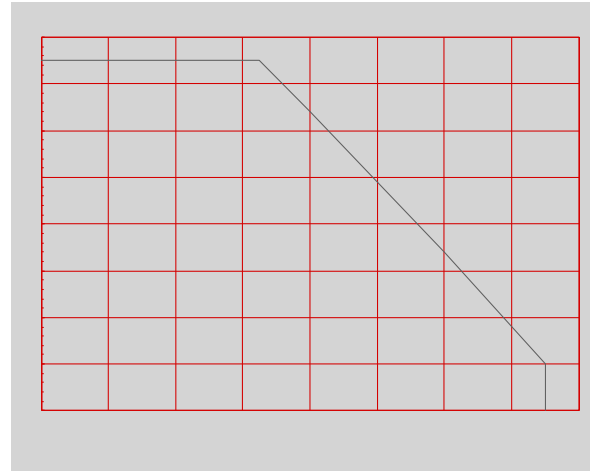
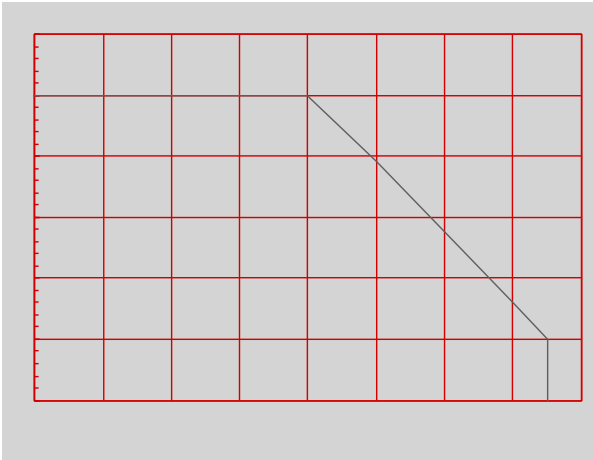

---



# Test Circuits

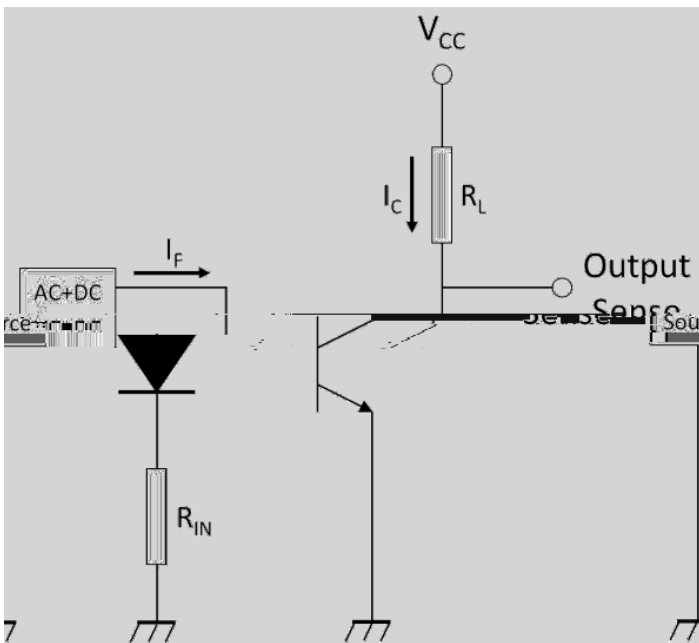
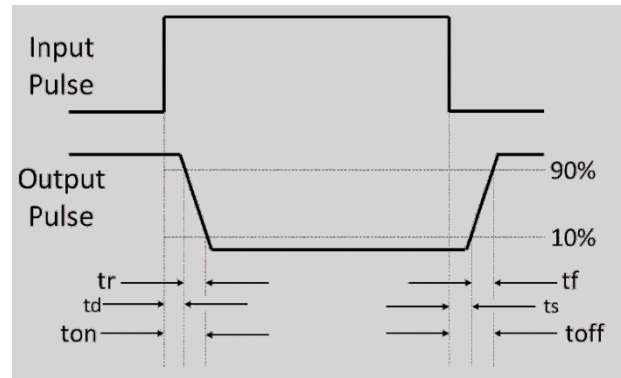
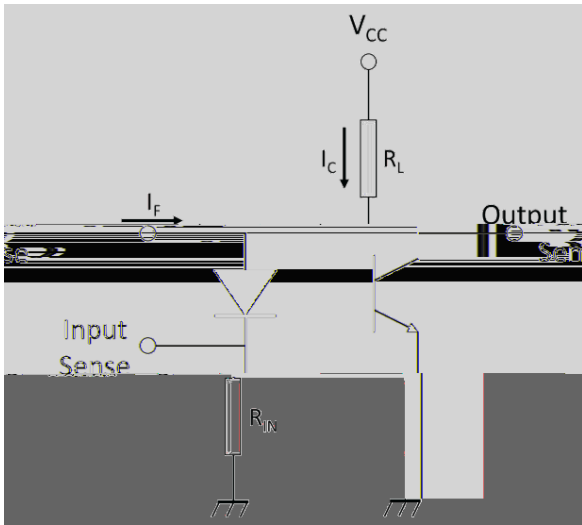







# REFLOW INFORMATION

