

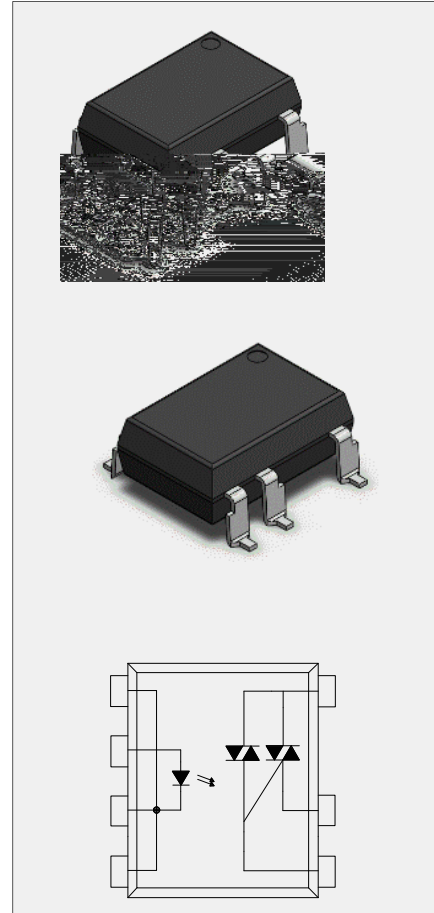

DESCRIPTION:



MAIN FEATURES:

ABSOLUTE MAXIMUM RATINGS

Parameter		Symbol	Value	Unit
			①	
		)		
		)		
		)		
	C	)		



Characteristics Curves

FIG.1:

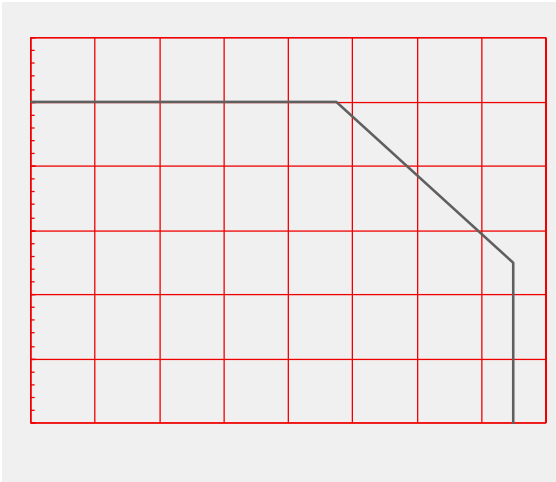

FIG.2:

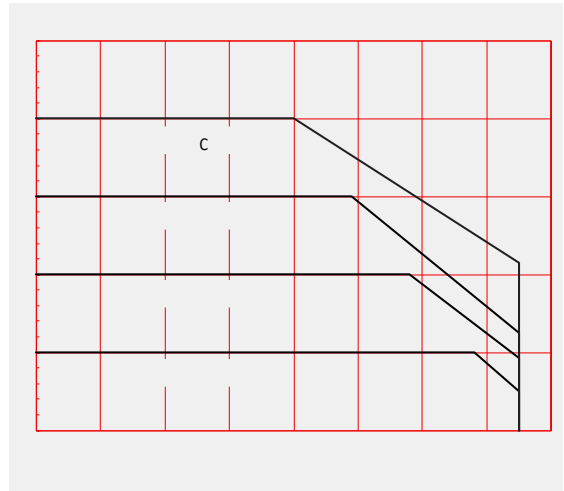

FIG.3:

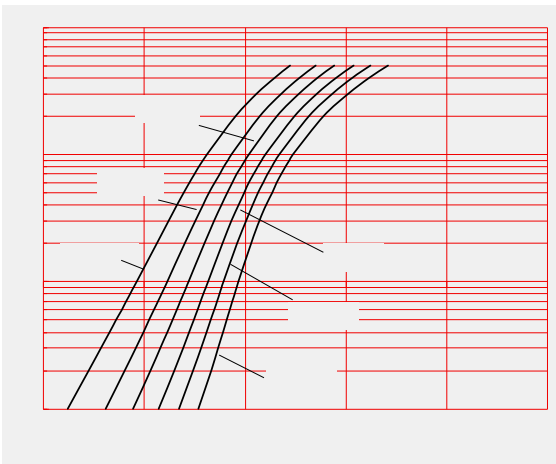

FIG.4:

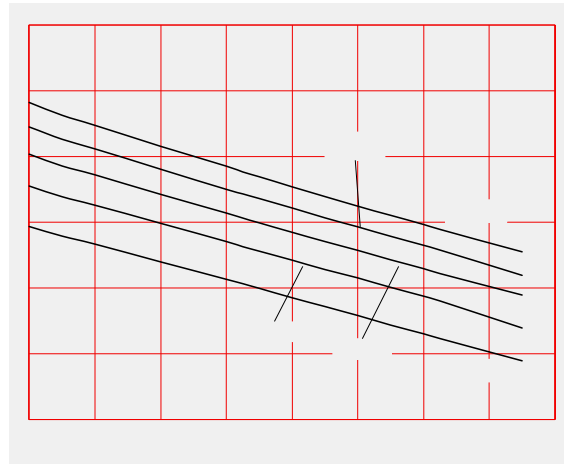

FIG.5:

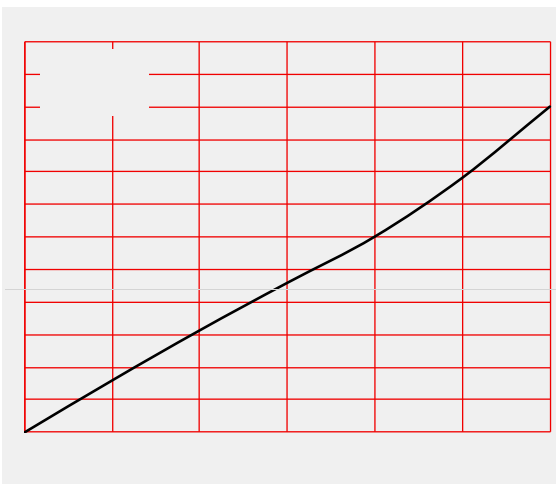

FIG.6:

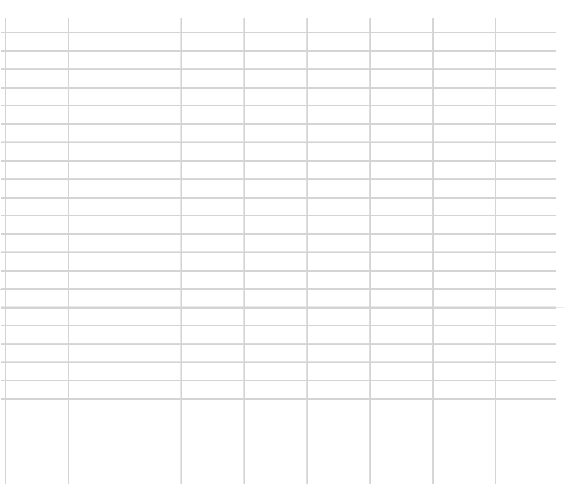

FIG.7:

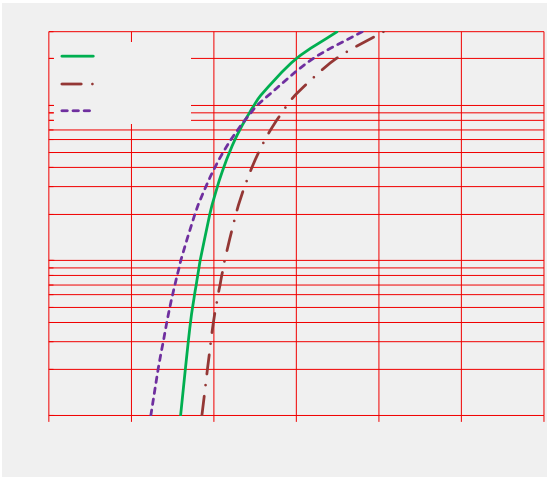

FIG.8:

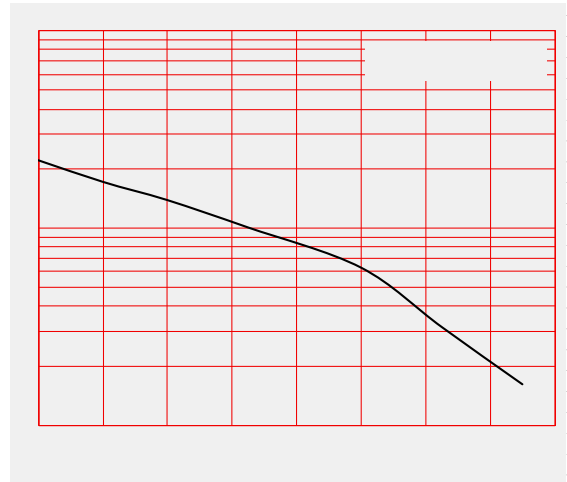
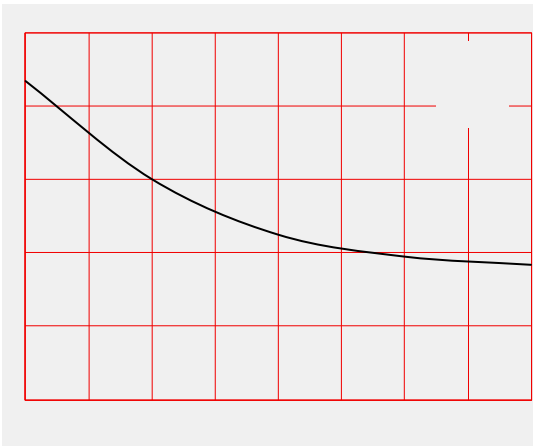

FIG.9:



TEST CIRCUITS

FIG.10:

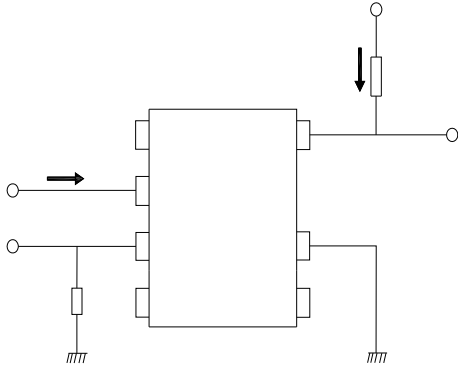
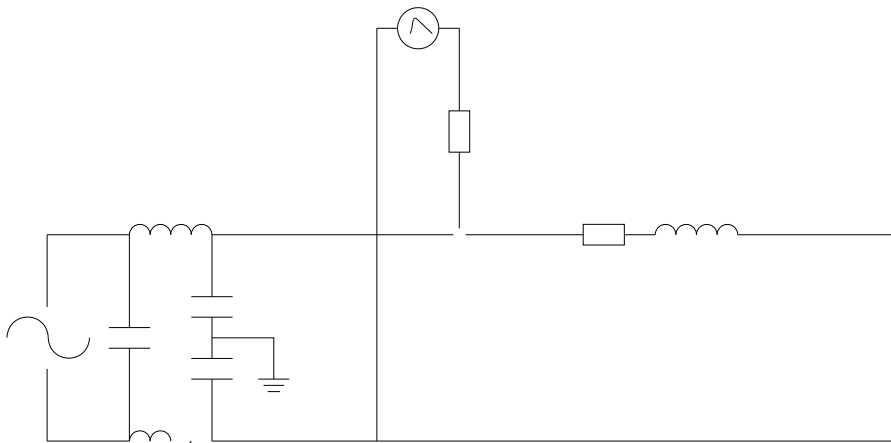

FIG.11:

FIG.12:





RECOMMENDED SOLDER MASK (Dimensions in mm unless otherwise stated)

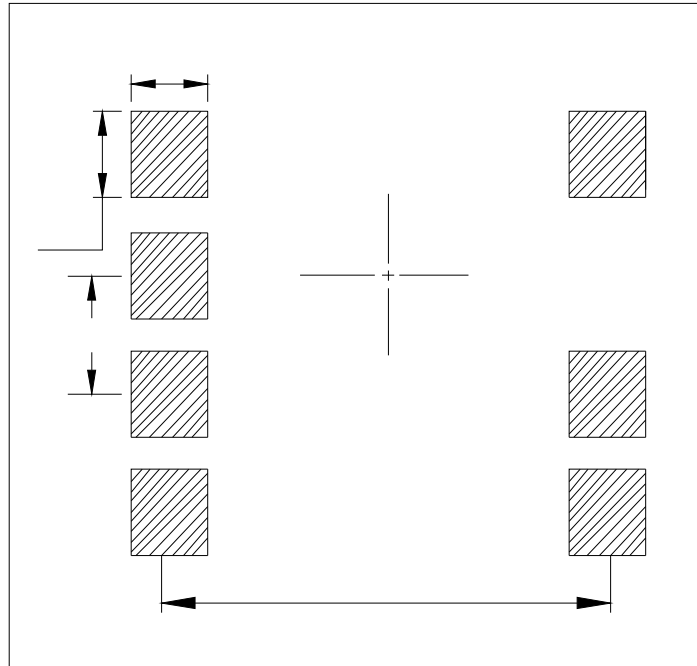

TUBE SPECIFICATIONS (Dimensions in mm unless otherwise stated)

Standard DIP

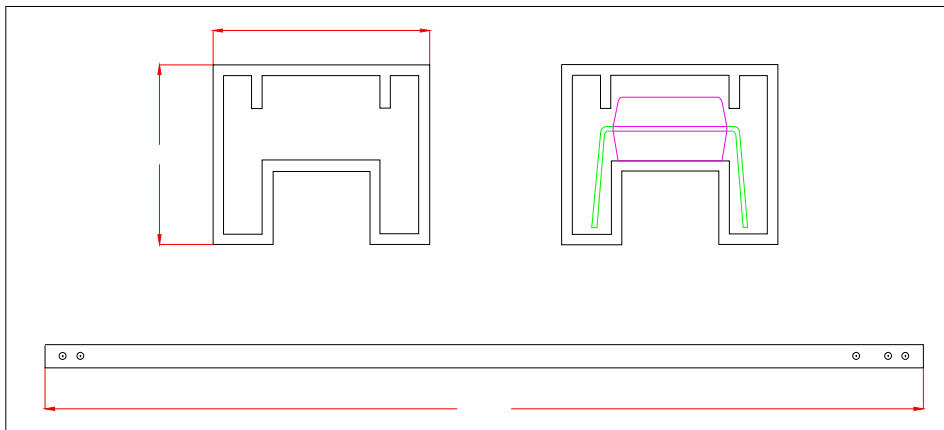

**CARRIER TAPE SPECIFICATIONS (Dimensions in mm unless otherwise stated)**

Option S/L

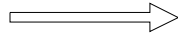
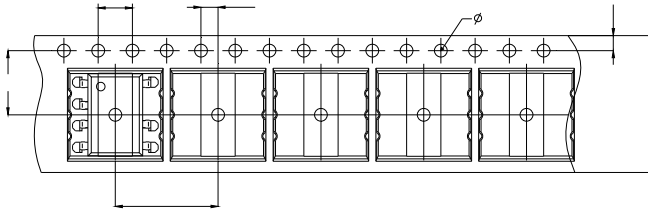

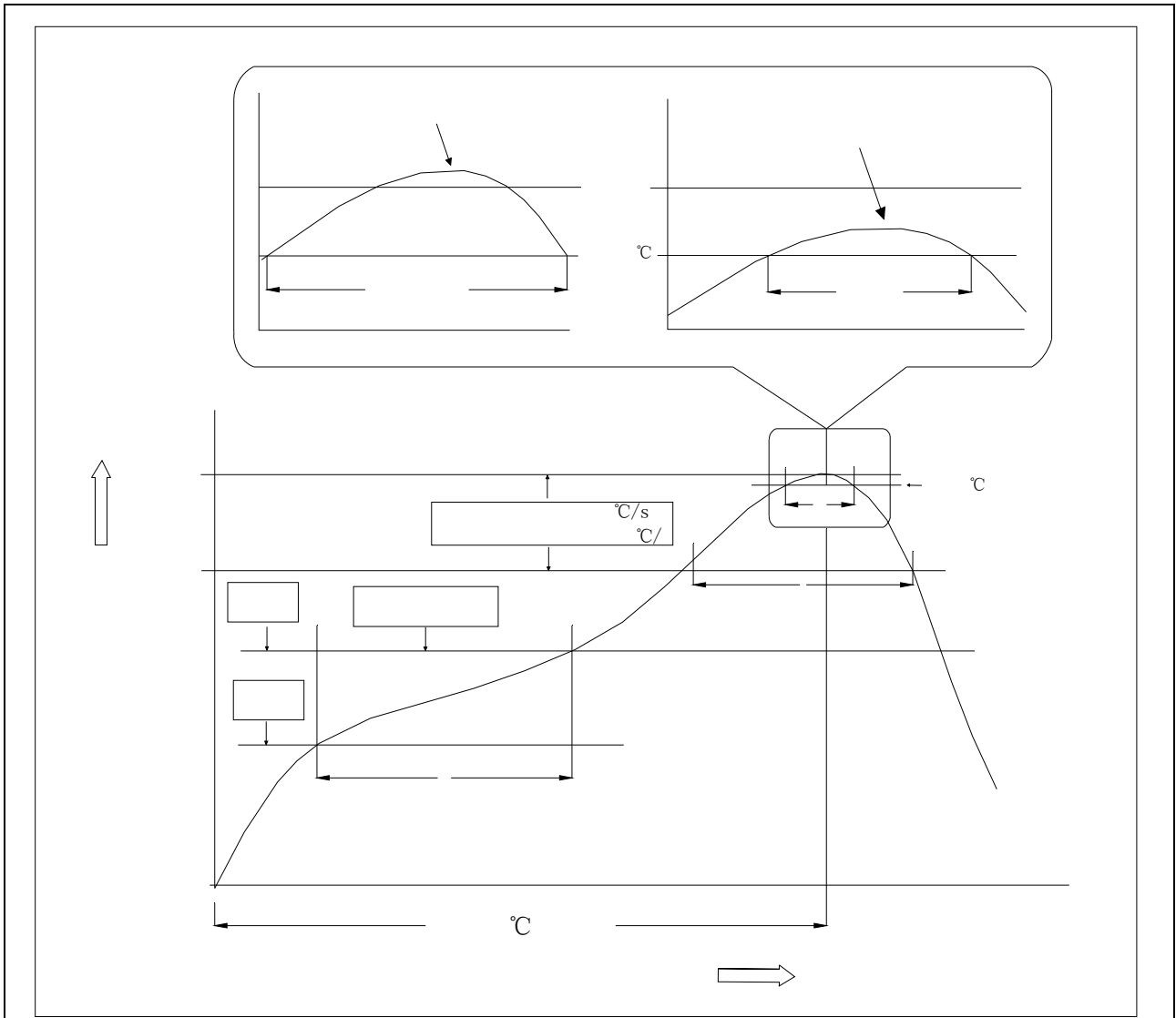

REFLOW INFORMATION

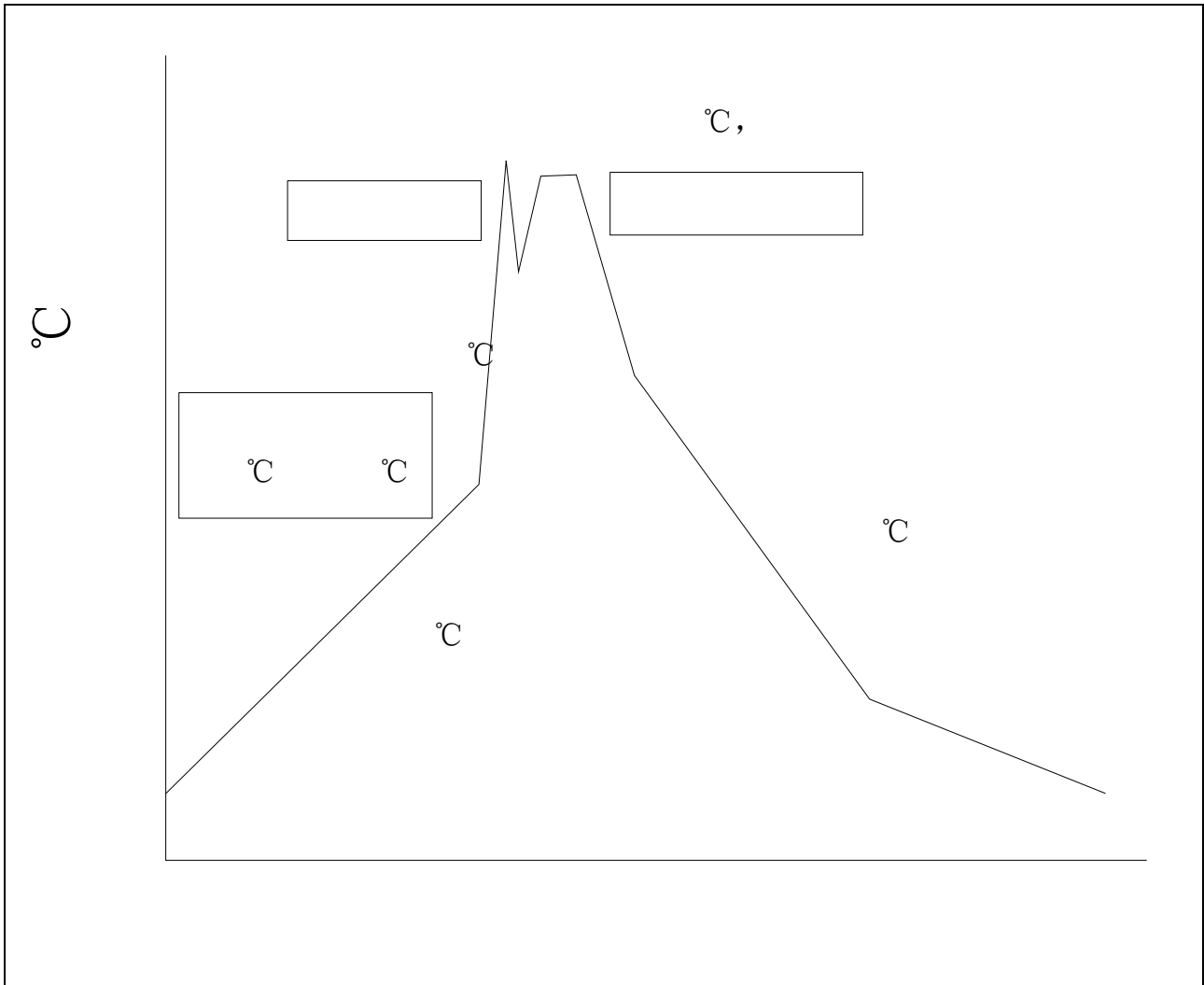

	°C
	°C
	°C
	°C
	°C °C °C
°C °C	
	°C

WAVE SOLDERING



<b>HAND SOLDERING BY SOLDERING IRON</b>	
	$\pm$ °C

