

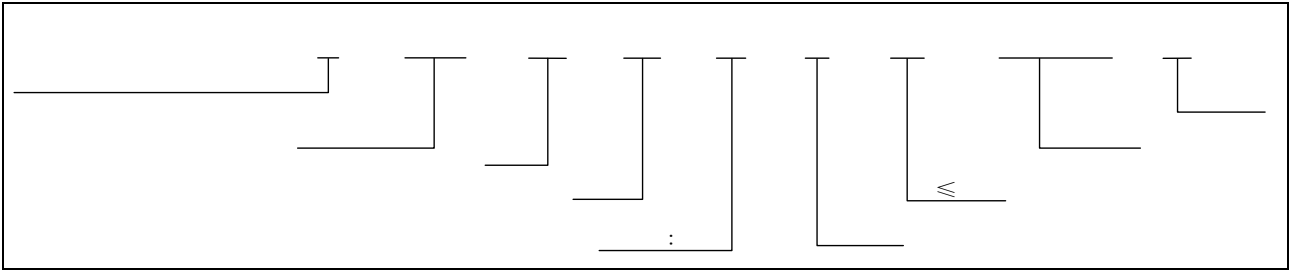

			°C
--	--	--	----

: 100μs pulse, 100Hzfrequency  
: AC for 1minute, R.H.=40~60%

Parameter	Symbol	Condition	Min.	Typ.	Max.	Unit



S-VSON4	2500 Units/Reel

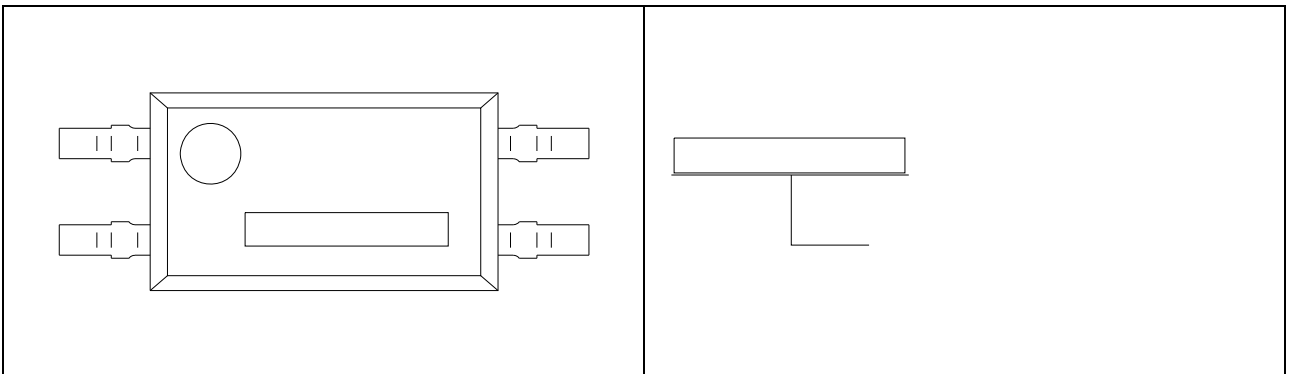

FIG.1:

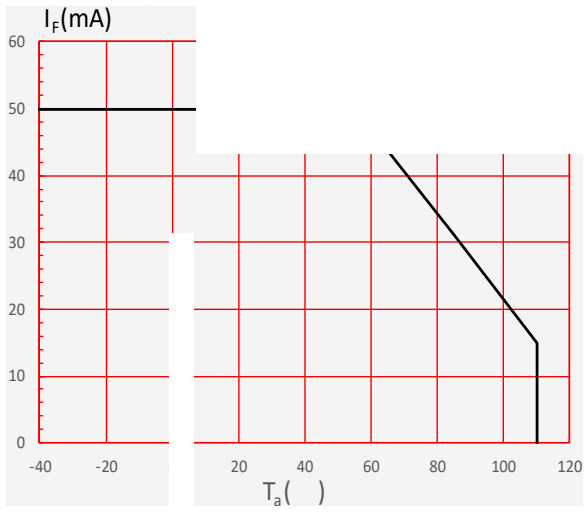

FIG.3:

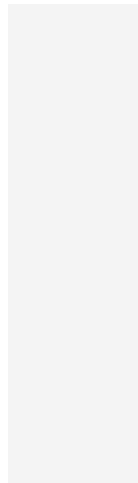

FIG.2:

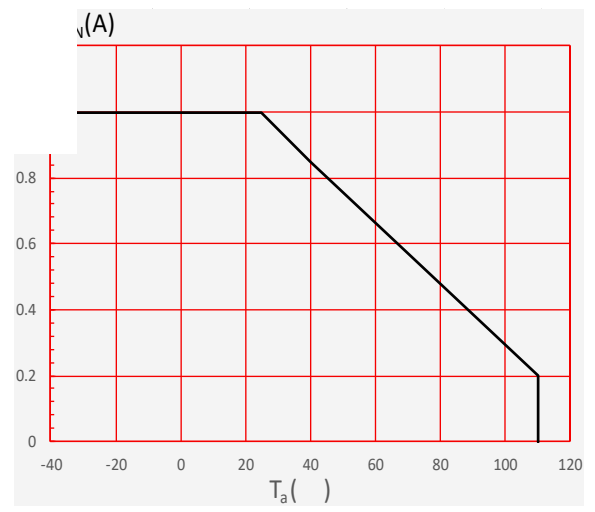
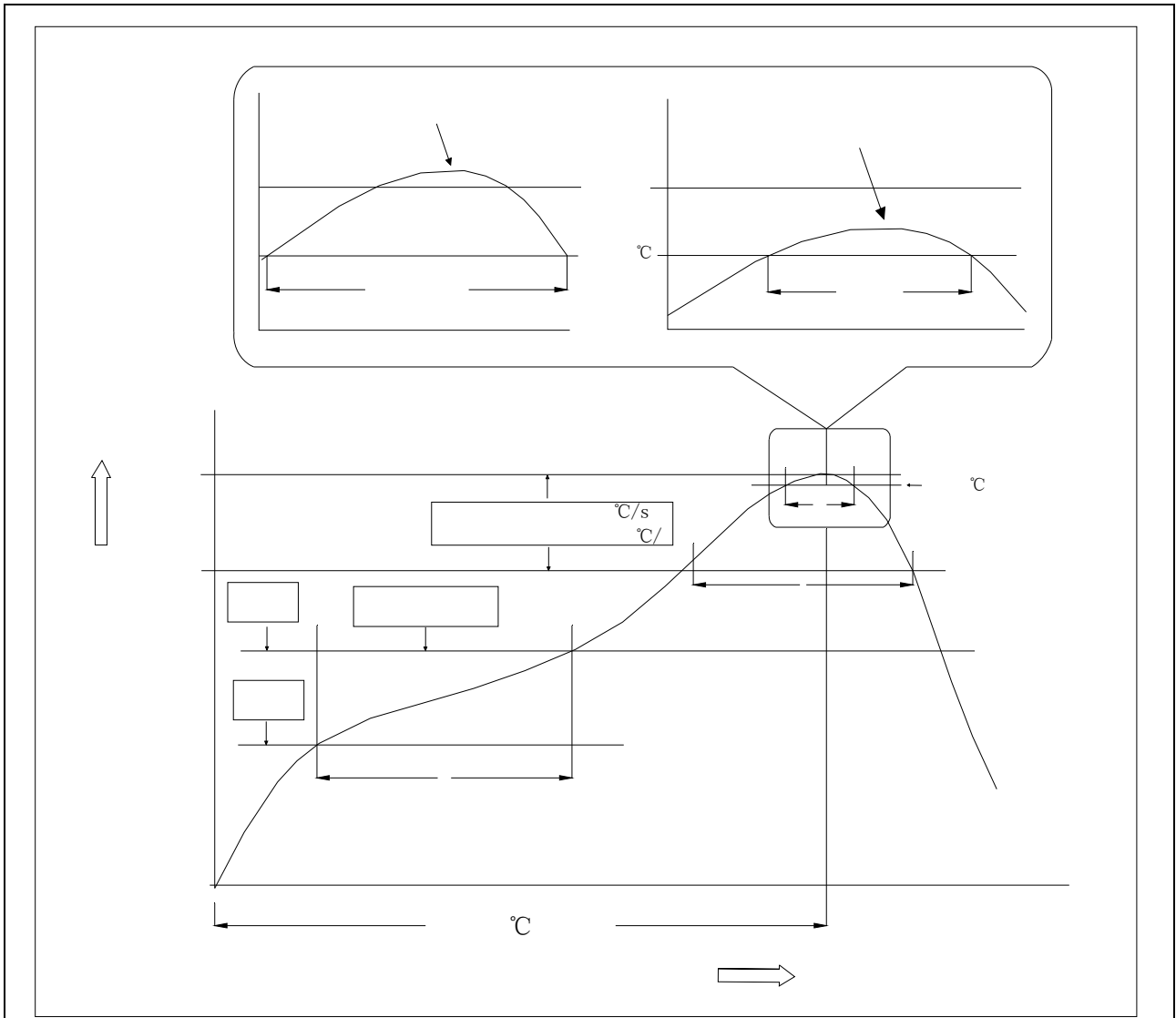

FIG.4:









Profile Feature	Sn-Pb Assembly Profile	Pb-Free Assembly Profile
	°C	°C
	°C	°C
	°C	°C
	°C	°C
	°C °C °C	°C °C °C
°C °C		
	°C	°C
°C		

