



JOC3120R Series

DC Input, 2.5A, Gate Driver Photo Coupler

Description

The JOC3120R series combine an AlGaAs infrared emitting diode as the emitter which is optically coupled to an integrated circuit with a power output stage in a plastic DIP8 package with different lead forming options.

Features

- High isolation 5000 VRMS
- DC input with a high speed driver
- Operating temperature range - 40 °C to 100 °C
- Rail to rail output
- REACH & RoHS compliance
- Halogen free (Optional)
- MSL class 1
- Regulatory Approvals
 - UL
 - VDE
 - CQC

Applications

- Isolated IGBT/Power MOSFET gate drive
- Industrial Inverter
- AC brushless and DC motor drives
- Induction Heating

SCHEMATIC

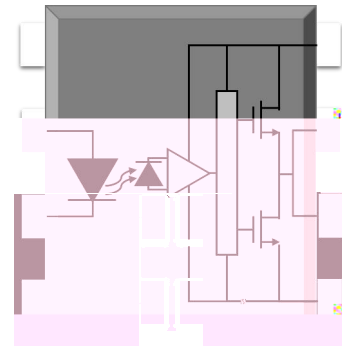

PIN DEFINITION

1.NC	8.VCC
2.Anode	7.VO
3.Cathode	6.VO
4.NC	5.GND

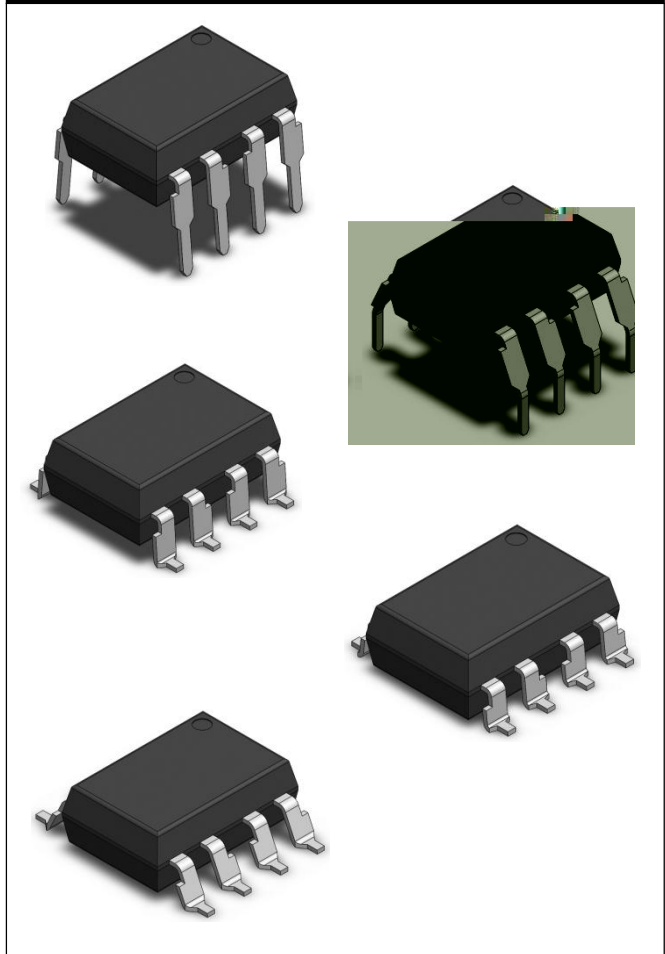

ABSOLUTE MAXIMUM RATINGS

PARAMETER	SYMBOL	VALUE	UNIT	Note
INPUT				
Forward Current	IF	25	mA	
Peak Forward Current	IFP	50	mA	1
Peak Transient Current	IF(trans)	1	A	2
Operating Frequency	f	50	kHz	
Reverse Voltage	VR	5	V	
Input Power Dissipation	PI	100	mW	
OUTPUT				
Supply Voltage	VCC	35	V	
Output Voltage	VO	35	V	
Peak Output Current	IO	2.5	A	
Output Power Dissipation	PO	250	mW	
COMMON				
Total Power Dissipation	Ptot	295	mW	
Isolation Voltage	Viso	5000	Vrms	3

RECOMMENDED OPERATION CONDITIONS

PARAMETER	SYMBOL	MIN.	MAX.	UNIT
Operating Temperature	TA	-40	100	°C
Supply Voltage	VCC	15	30	V
Input Current (ON)	IF(ON)	7	16	mA
Input Voltage (OFF)	VF(OFF)	0	0.8	V

ELECTRICAL OPTICAL CHARACTERISTICS (VCC=30V, VEE=GND, TA=25°C unless specified otherwise)

PARAMETER	SYMBOL	MIN.	TYP.	MAX.	UNIT	TEST CONDITION	NOTE
INPUT CHARACTERISTICS							
Forward Voltage	VF	-	1.38	1.8	V	IF=10mA	
Reverse Current	IR	-	-	10	μA	VR=5V	
Input Capacitance	Cin	-	13	-	pF	V=0, f=1MHz	
OUTPUT CHARACTERISTICS							
High Level Supply Current	ICCH	-	1.66	3	mA	IF= 7mA to 10mA, VO= Open	
Low Level Supply Current	ICCL	-	1.8	3	mA	VF = 0 to 0.8V, VO= Open	
TRANSFER CHARACTERISTICS							
High Level Output Voltage	VOH	VCC-0.3	VCC-0.1	-	V	IF= 10mA, IO= -100mA	
Low Level Output Voltage	VOL	-	VEE+0.1	VEE+0.25	V	IF= 0mA, IO= 100mA	
High Level Output Current	IOPH	-1	-	-	A	VO= VCC-1.5V	
		-2.5	-	-	A	VO= VCC-4V	
Low Level Output Current	IOPL	1	-	-	A	VO= VEE+1.5V	
		2.5	-	-	A	VO= VEE+4V	
Input Threshold Current	IFLH	-	2.38	5	mA	IO= 0mA, VO> 5V	
Input Threshold Voltage	VFHL	0.8	-	-	V	IO= 0mA, VO< 5V	
Under Voltage Lockout Threshold	VUVLO+	11	13.01	13.5	V	IO= 10mA, VO> 5V	
	VUVLO-	9.5	11.01	12	V	IO= 10mA, VO< 5V	
Isolation Resistance	Riso	10 ¹²	10 ¹⁴	-	Ω	DC500V, 40 ~ 60% R.H.	
Floating Capacitance	CIO	-	1.0	-	pF	V=0, f=1MHz	

ELECTRICAL OPTICAL CHARACTERISTICS (VCC=30V, VEE=GND, TA=25°C unless specified otherwise)

PARAMETER	SYMBOL	MIN.	TYP.	MAX.	UNIT	TEST CONDITION	NOTE
SWITCHING CHARACTERISTICS							
Propagation Delay Time to Output Low Level	TPHL	50	103	500	ns		
Propagation Delay Time to Output High Level	TPLH	50	83	500	ns	IF= 7 to 16mA, CL= 10nF, RL= 10Ω,	
Pulse Width Distortion	TPHL-TPLH	-	20	200	ns	f= 10kHz, Duty = 50%, TA= 25 °C	
Propagation Delay Skew	tPSK	-100	-	100	ns		
Rise Time	tr	-	13	-	ns		
Fall Time	tf	-	13	-	ns		
UVLO Turn On Delay	tUVLO(ON)	-	1.6	-	μs	IF= 10mA, VO> 5V	
UVLO Turn Off Delay	tUVLO(OFF)	-	0.4	-	μs	IF= 10mA, VO< 5V	

Common Mode Transient

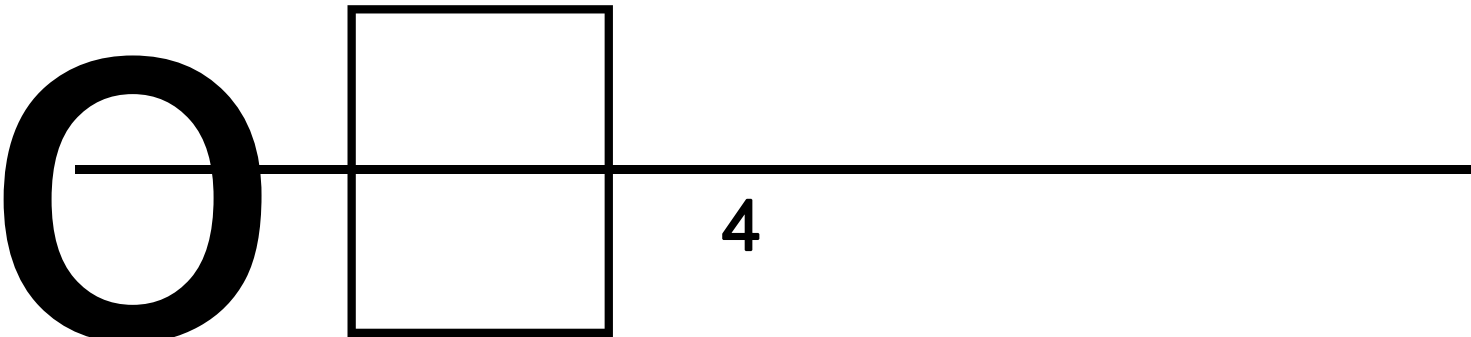

CHARACTERISTIC CURVES

Fig.1 Forward Current vs. Forward Voltage

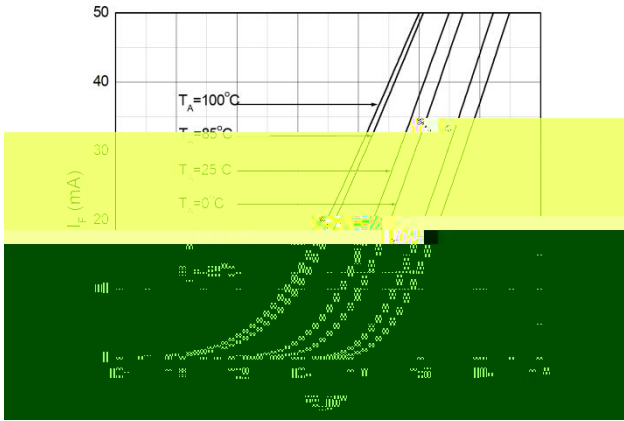

Fig.2 Forward Voltage vs. Ambient Temperature

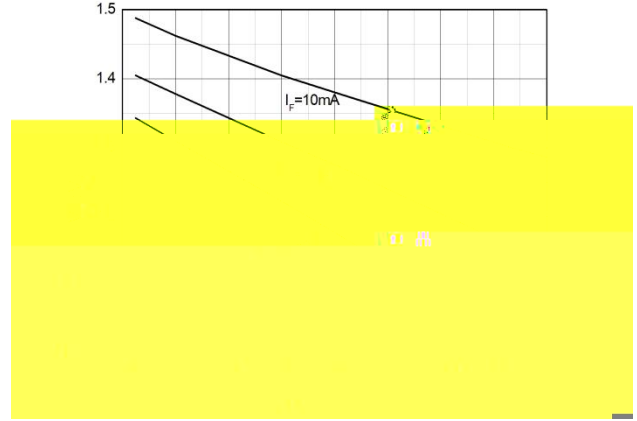

Fig.3 Supply Current vs. Ambient Temperature

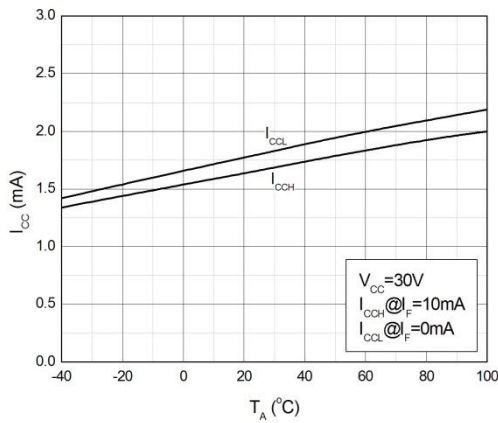

Fig.4 Supply Current vs. Supply Voltage

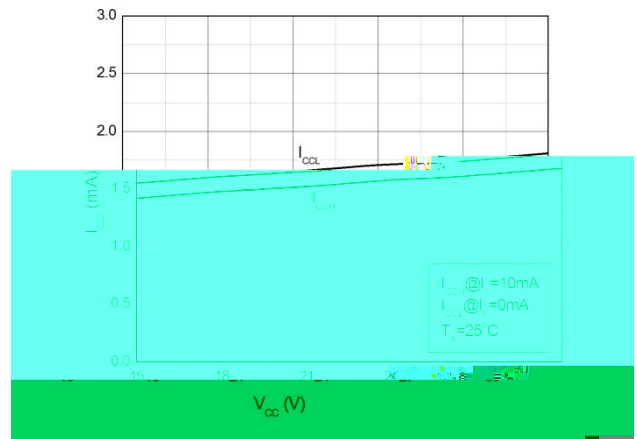

Fig.5 High Level Output Voltage vs. High Level Output Current

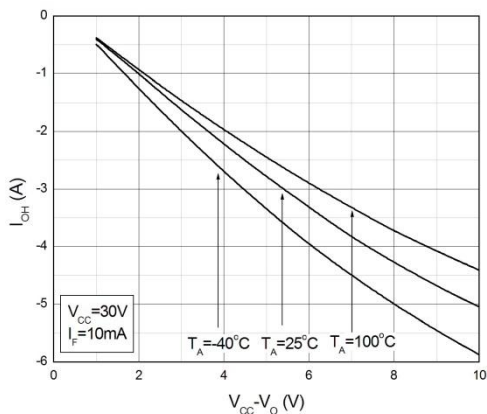
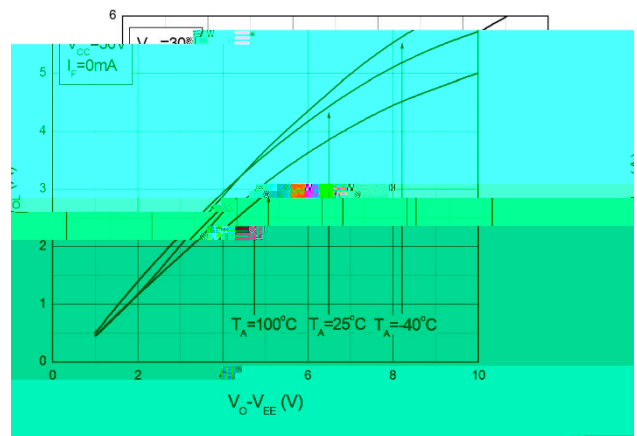

Fig.6 Low Level Output Voltage vs. Low Level Output Current



CHARACTERISTIC CURVES

Fig.7 High Level Output Voltage vs. Ambient Temperature

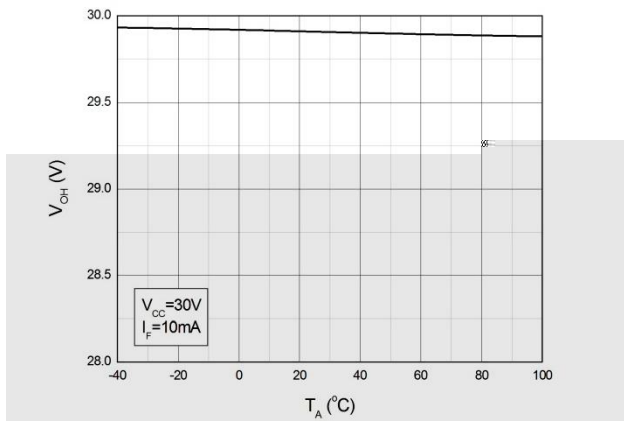

Fig.8 Low Level Output Voltage vs. Ambient Temperature

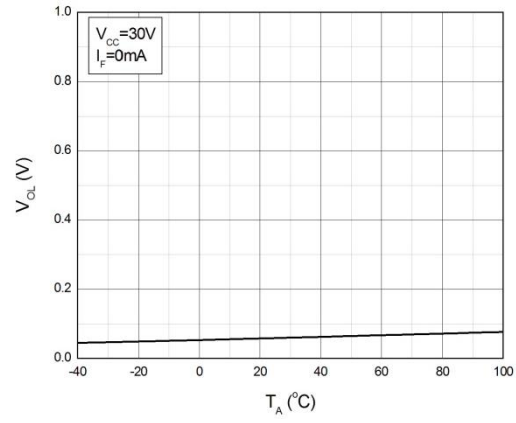

Fig.9 Output Voltage vs. Forward Current

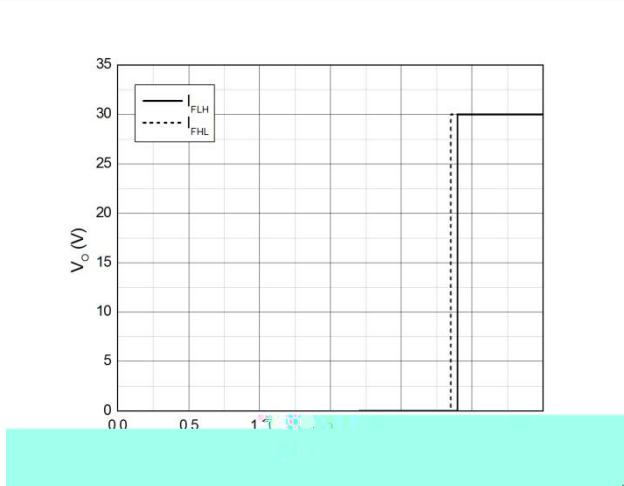

Fig.10 Output Voltage vs. Supply Voltage

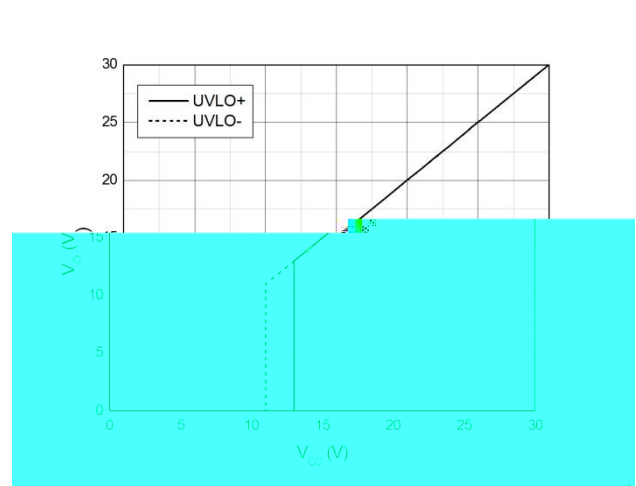

Fig.11 Forward Current vs. Ambient Temperature

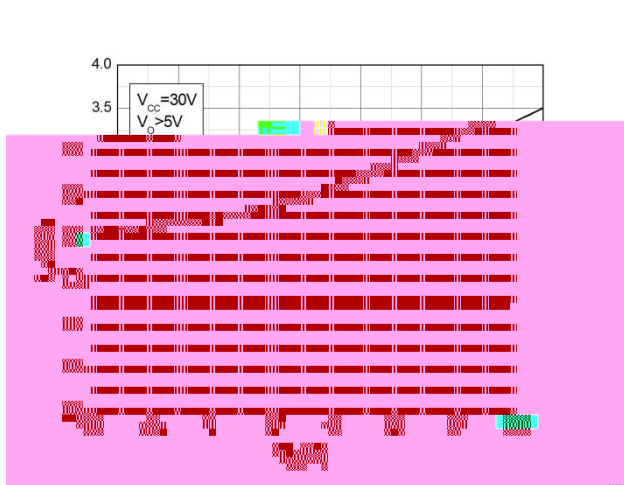
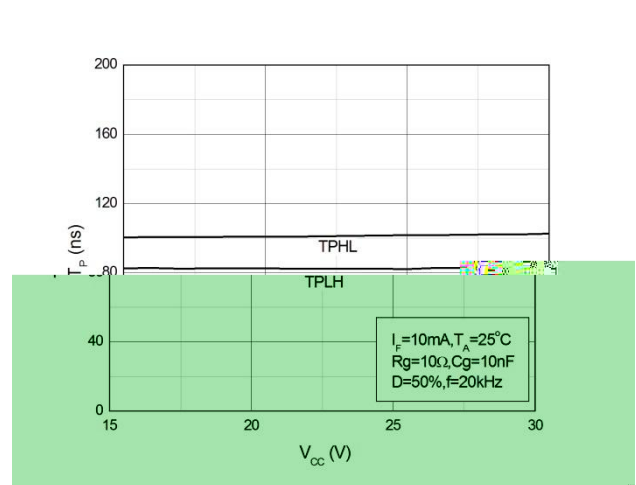

Fig.12 Propagation Delay vs. Supply Voltage



CHARACTERISTIC CURVES

Fig.13 Propagation Delay vs. Forward Current

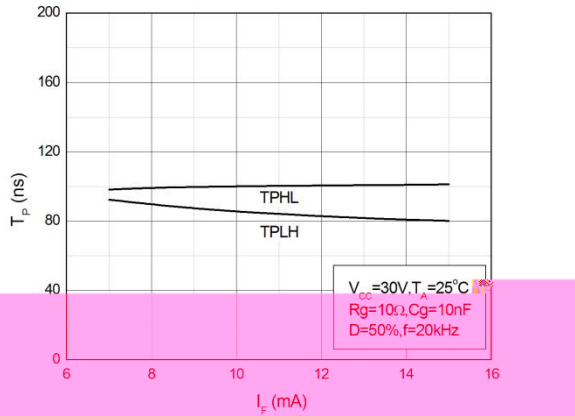

Fig.14 Propagation Delay vs. Ambient Temperature

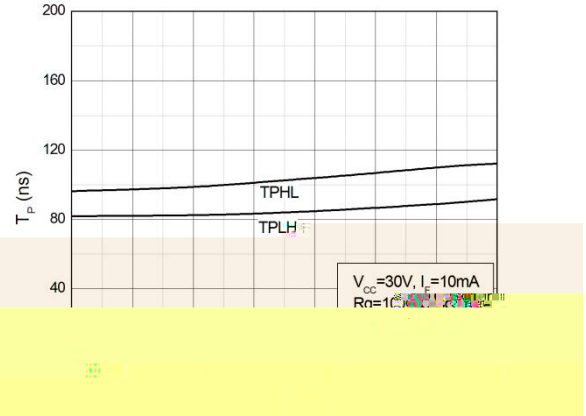

Fig.15 Propagation Delay vs. Load Resistance

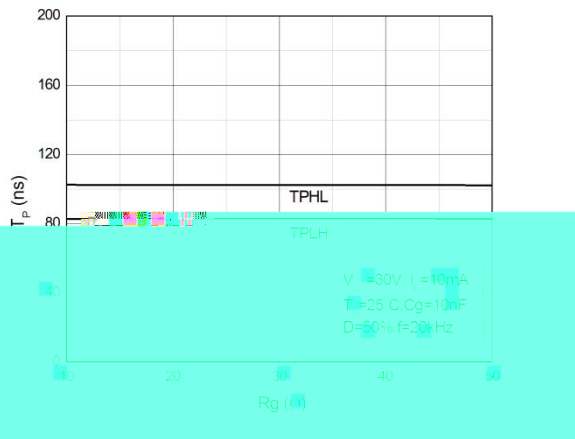
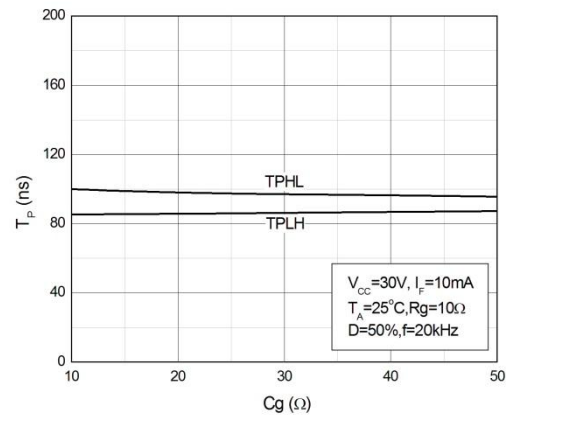

Fig.16 Propagation Delay vs. Load Capacitance



TEST CIRCUITS

Fig.17 Test Circuits for IOH

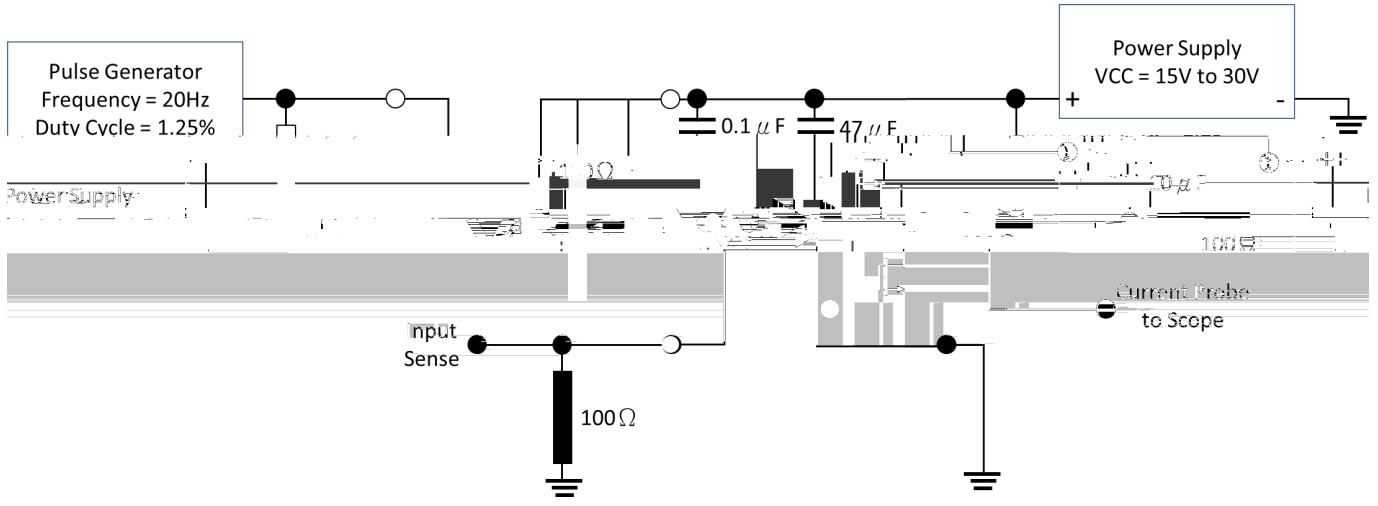
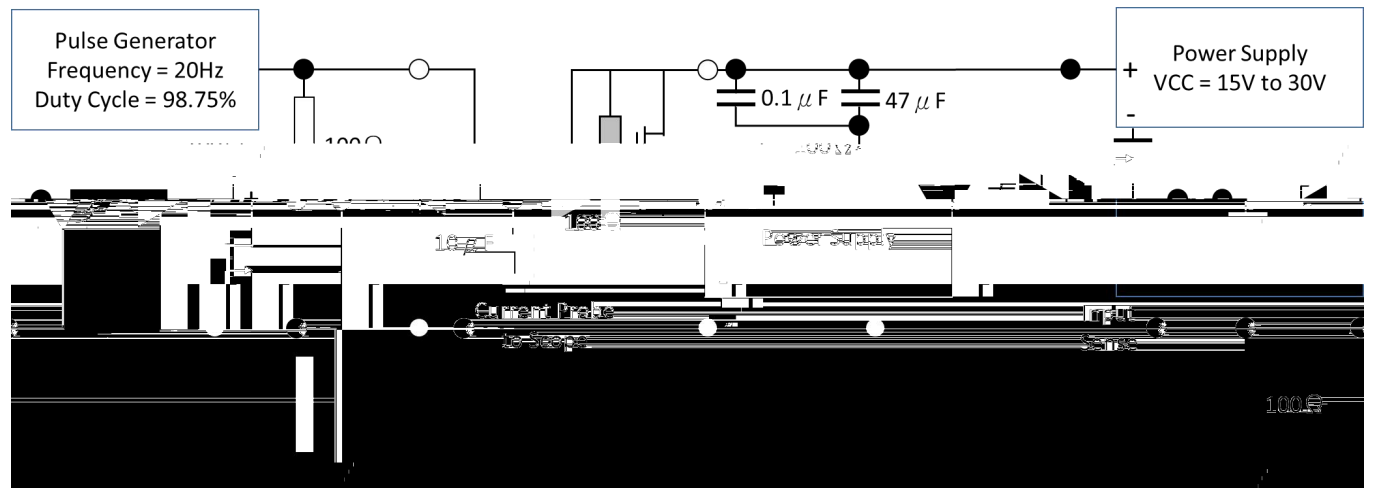

Fig.18 Test Circuits for IOL



TEST CIRCUITS

Fig.19 Test Circuits for TPHL, TPLH, tr, tf

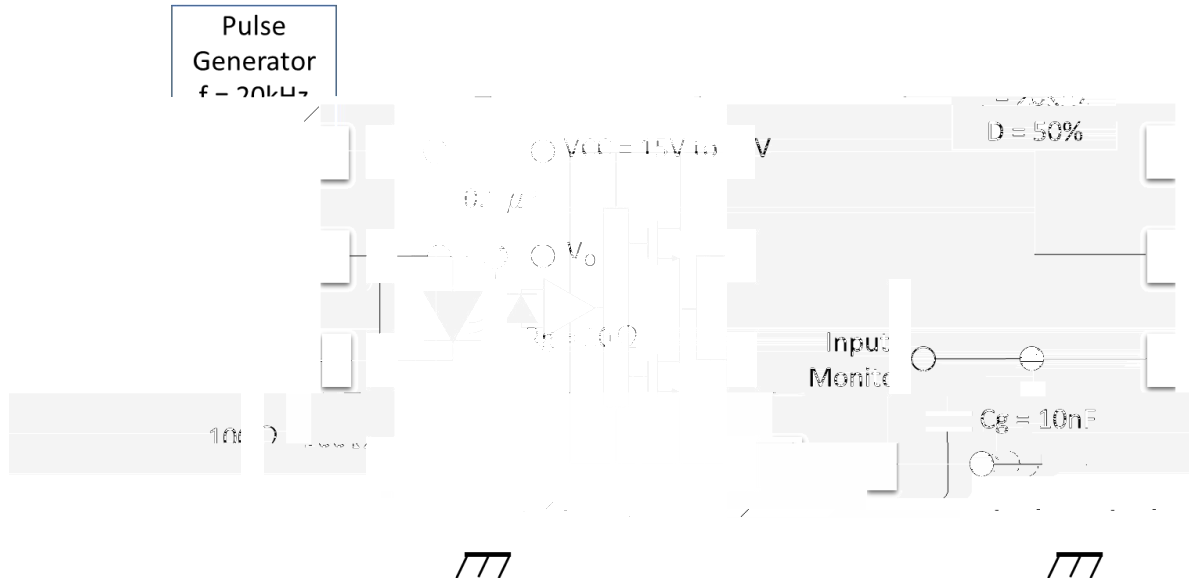
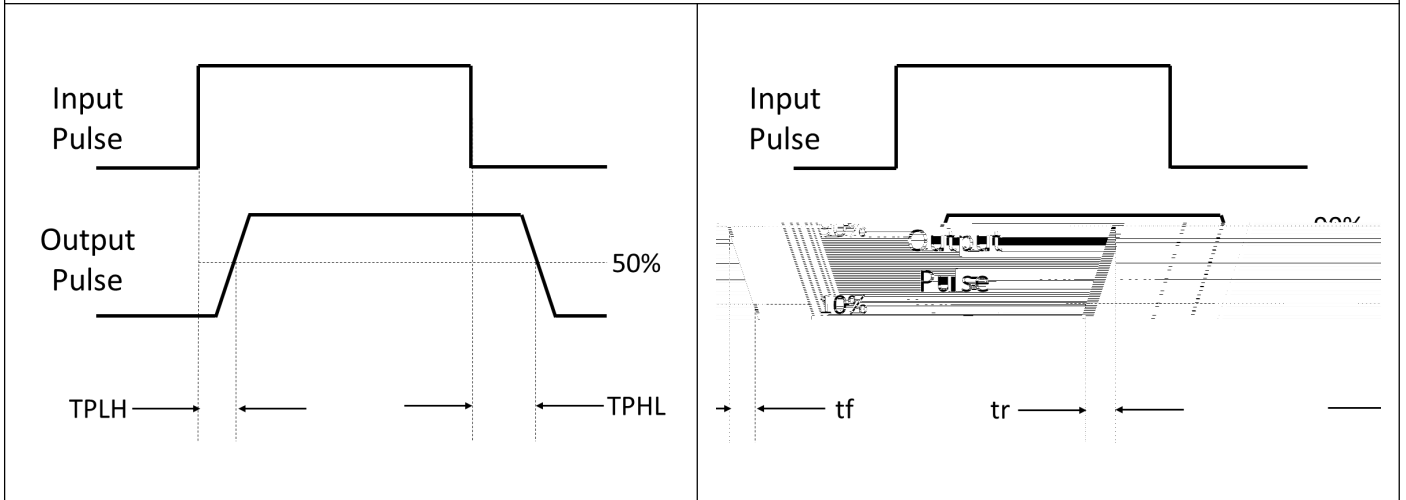

Fig.20 Waveforms of TPHL, TPLH, tr, tf



TEST CIRCUITS

Fig.21 Test Circuits for Common Mode Transient Immunity

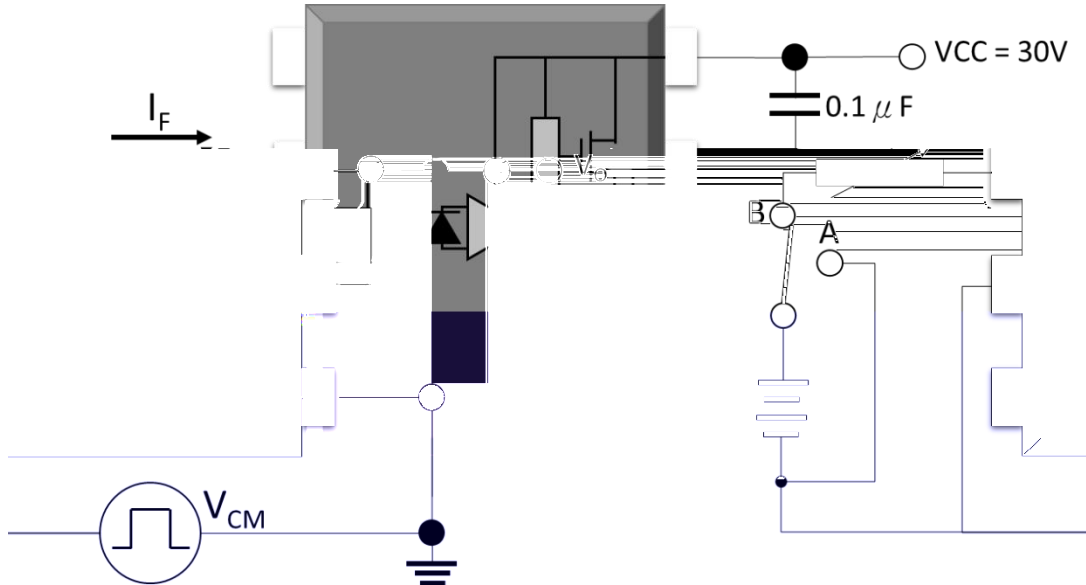
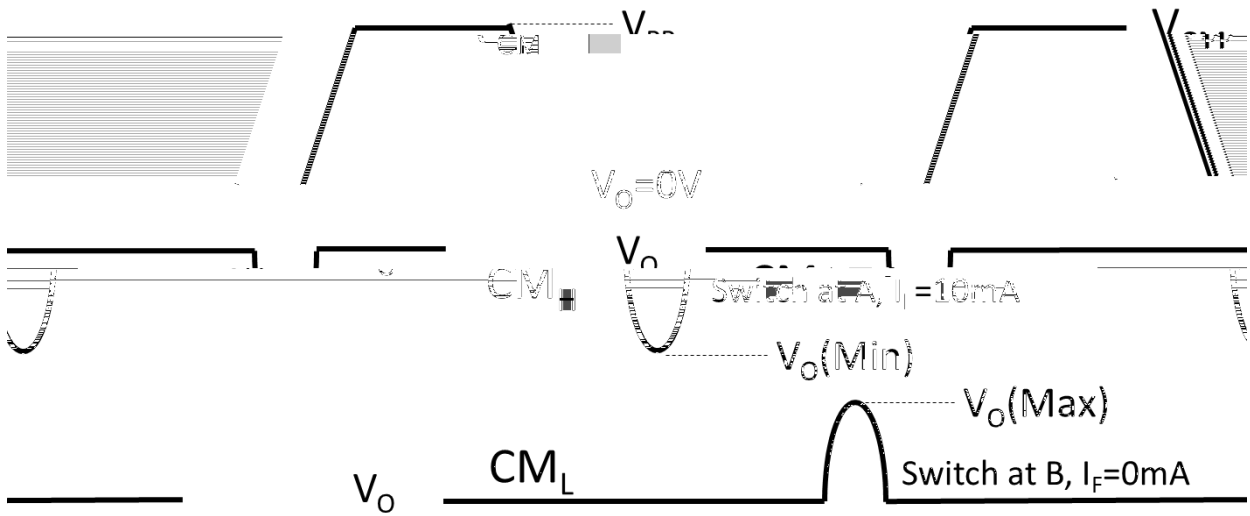
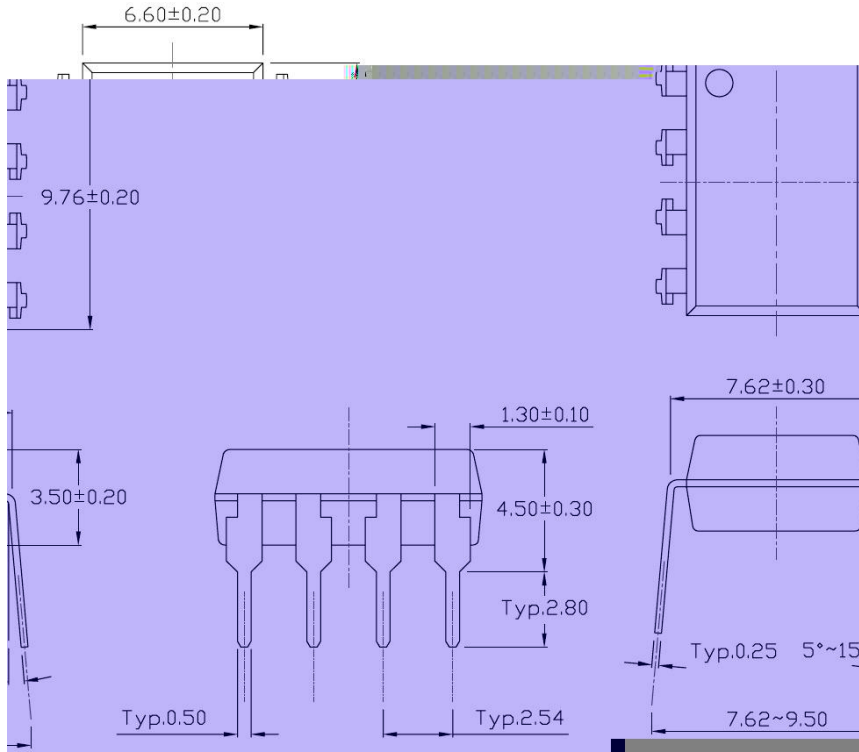

Fig.22 Waveforms of Common Mode Transient Immunity



PACKAGE DIMENSIONS Dimensions in mm unless otherwise stated)

Standard DIP – Through Hole (DIP Type)



Gullwing (400mil) Lead Forming – Through Hole (M Type)

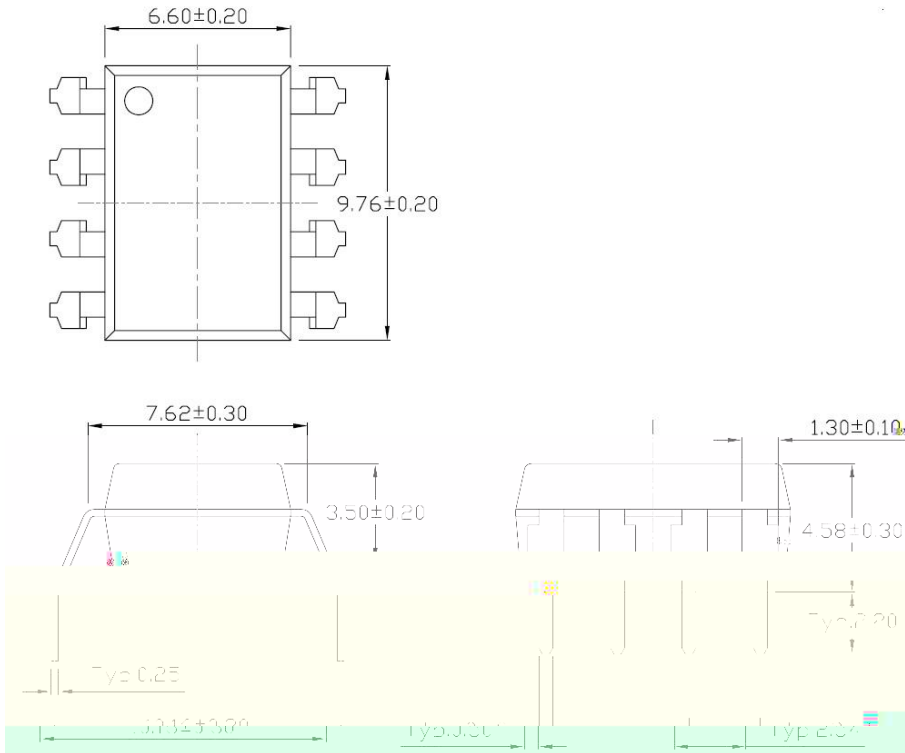

PACKAGE DIMENSIONS Dimensions in mm unless otherwise stated)

Surface Mount Lead Forming (S Type)

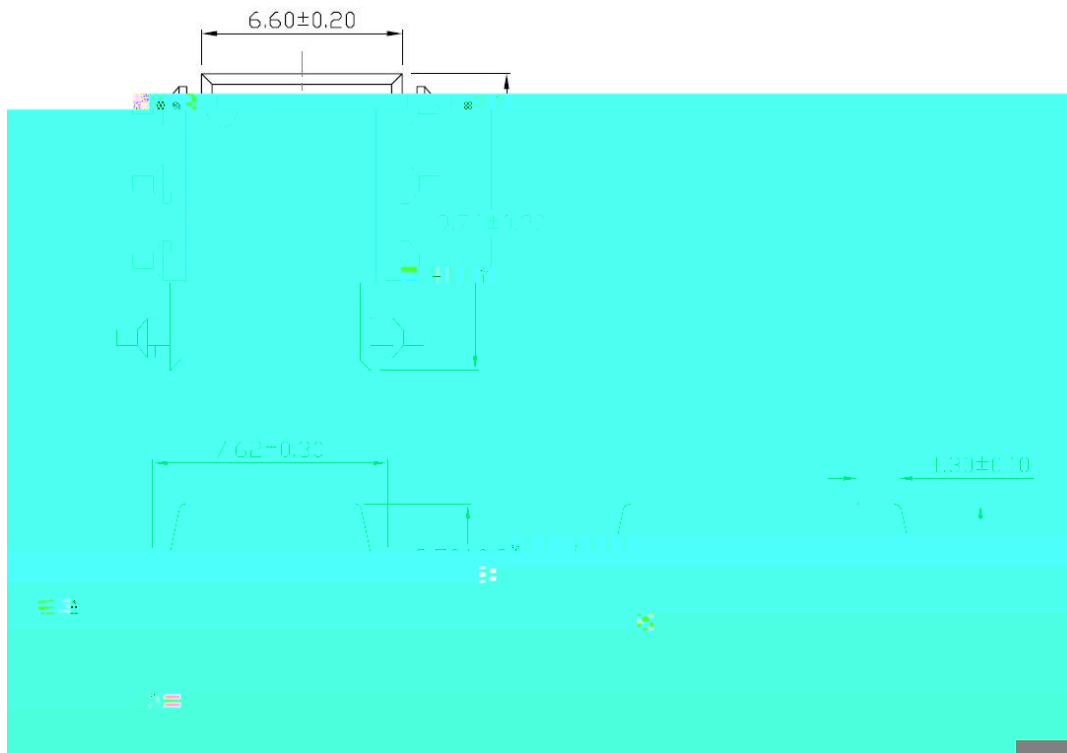

Surface Mount (Low Profile) Lead Forming (SL Type)

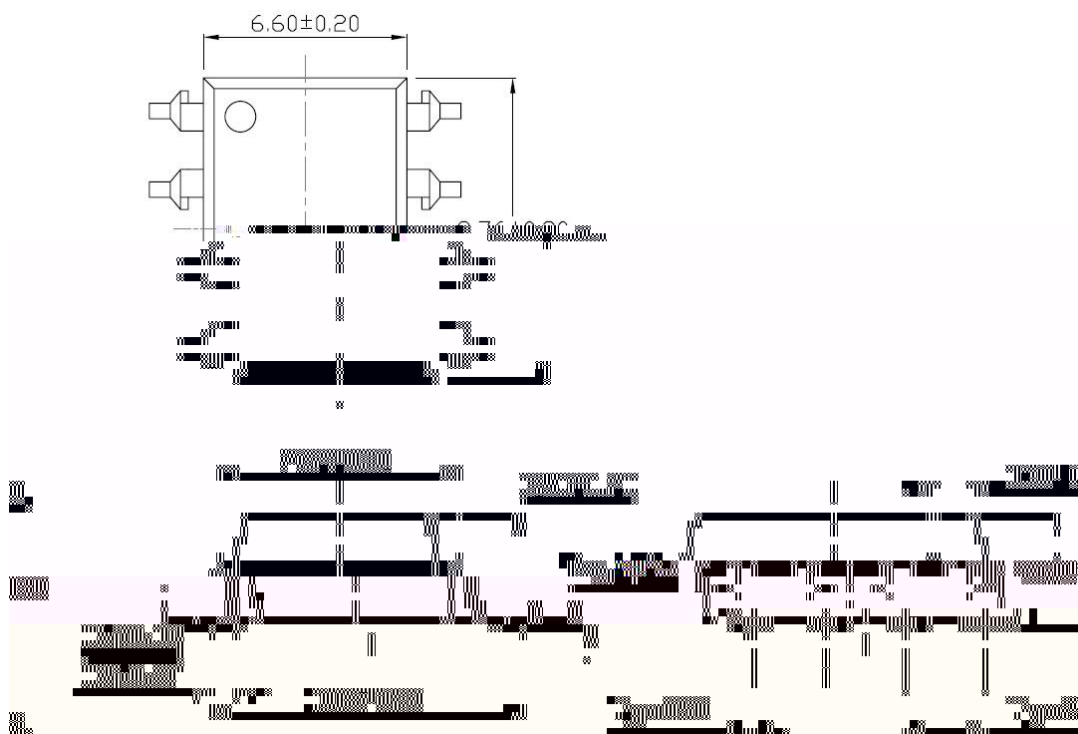

PACKAGE DIMENSIONS Dimensions in mm unless otherwise stated)

Surface Mount (Gullwing) Lead Forming (SLM Type)

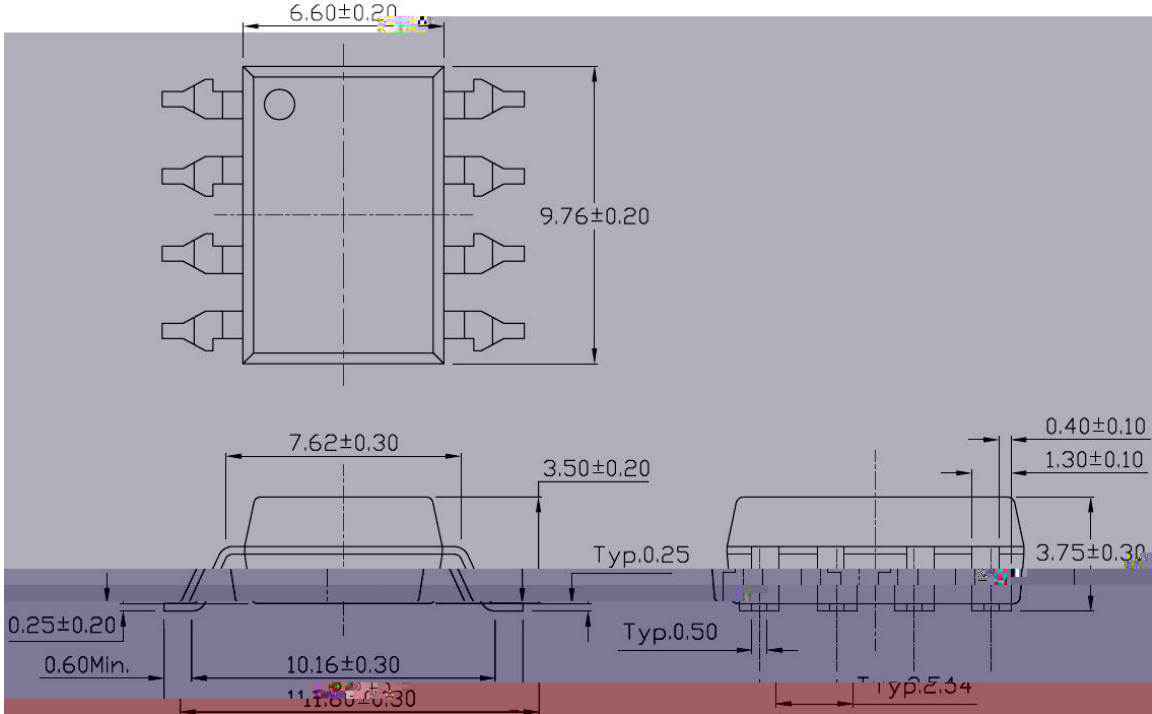

Recommended Solder Mask Dimensions in mm unless otherwise stated)

Surface Mount Lead Forming & Surface Mount (Low Profile) Lead Forming

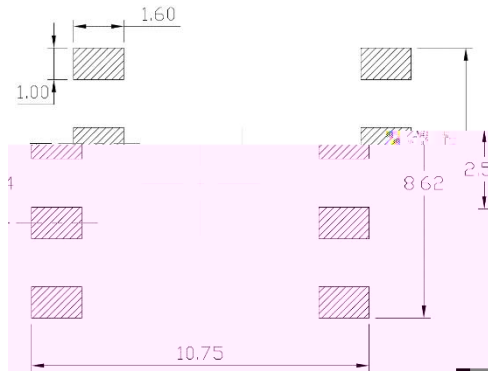

Surface Mount (Gullwing) Lead Forming

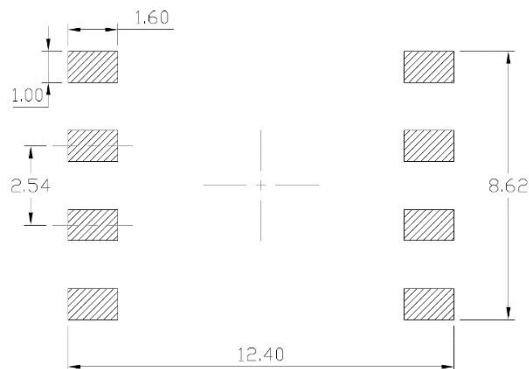

TUBE SPECIFICATIONS Dimensions in mm unless otherwise stated)

BOX SPECIFICATIONS Tube Type)

Inner Box

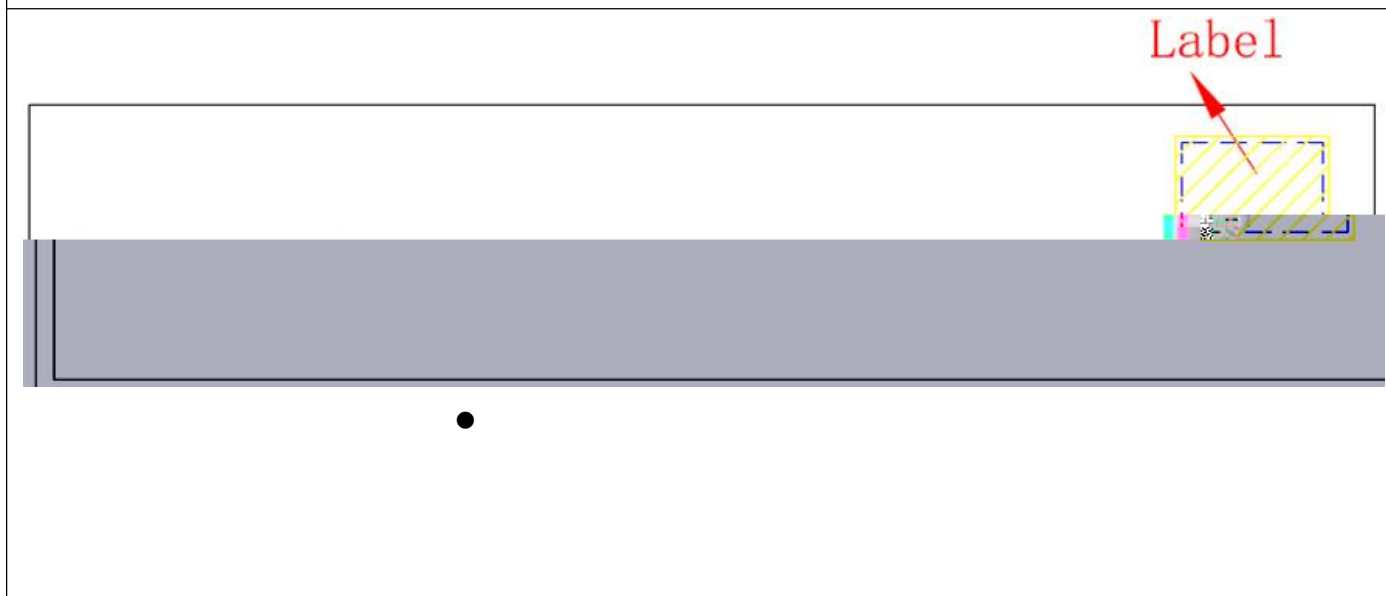

Outer Box

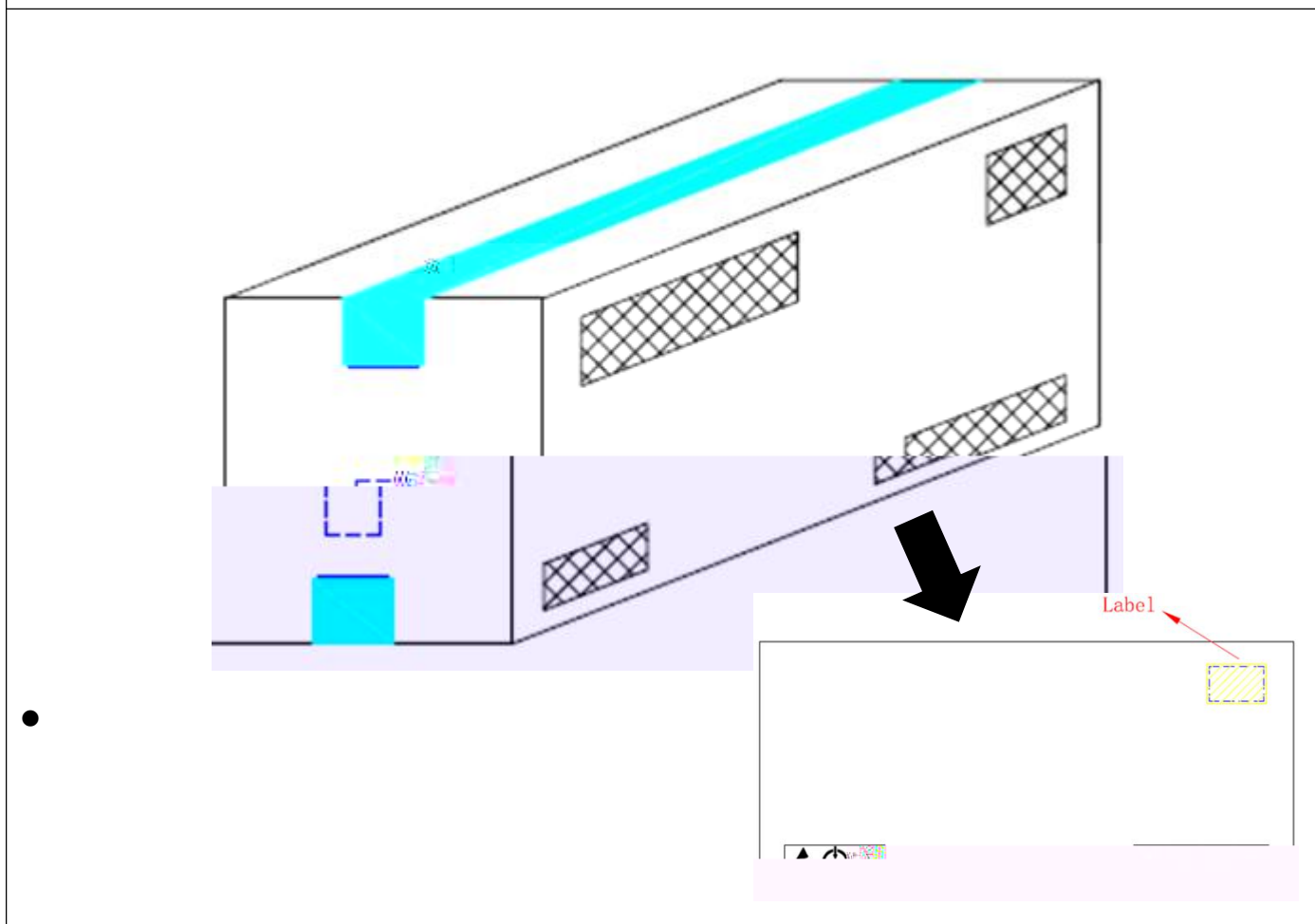

Carrier Tape Specifications Dimensions in mm unless otherwise stated)

Carrier Tape Specifications Dimensions in mm unless otherwise stated)

Option SLM(T1)

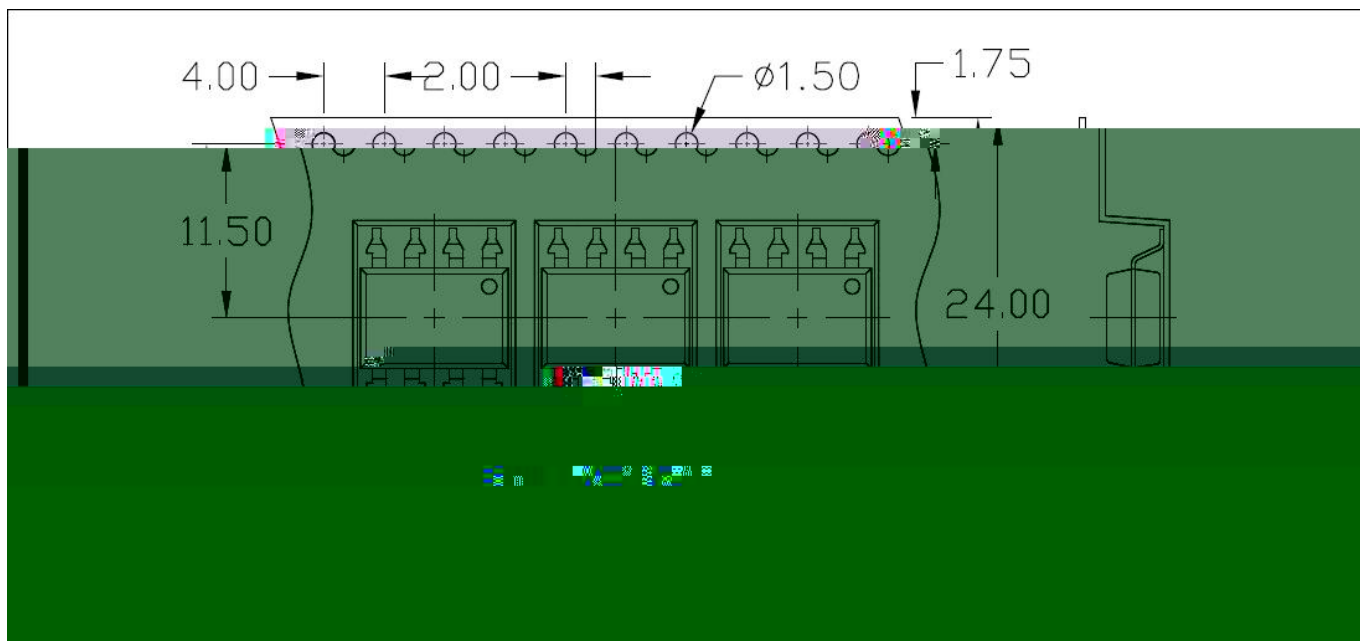

Option SLM(T2)

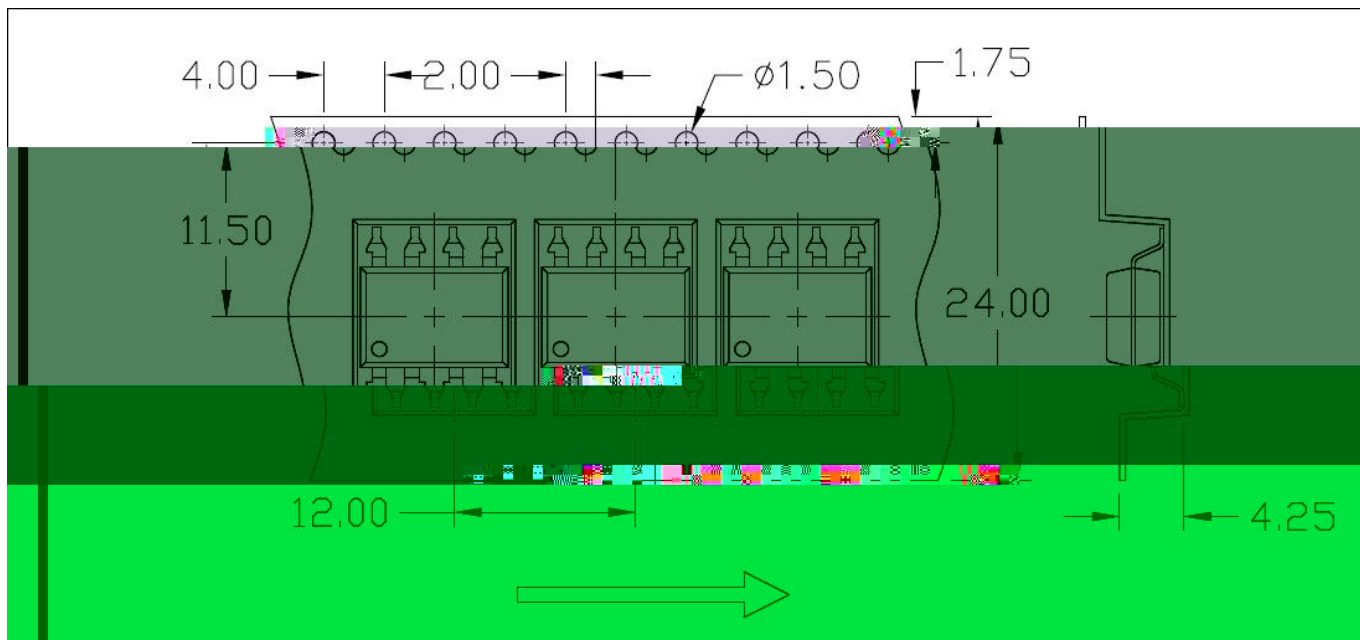

REEL SPECIFICATIONS Dimensions in mm unless otherwise stated)

Option S & Option SL

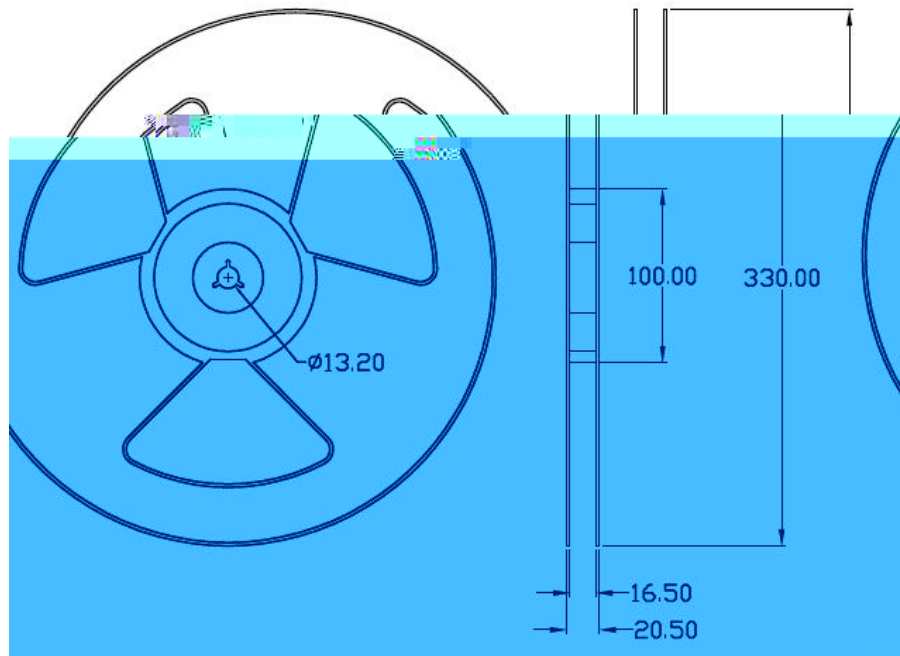

BOX SPECIFICATIONS Reel Type)

Inner Box

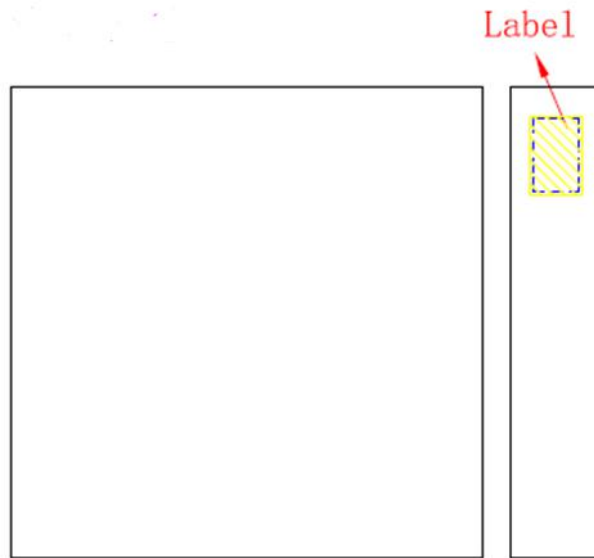

Outer Box

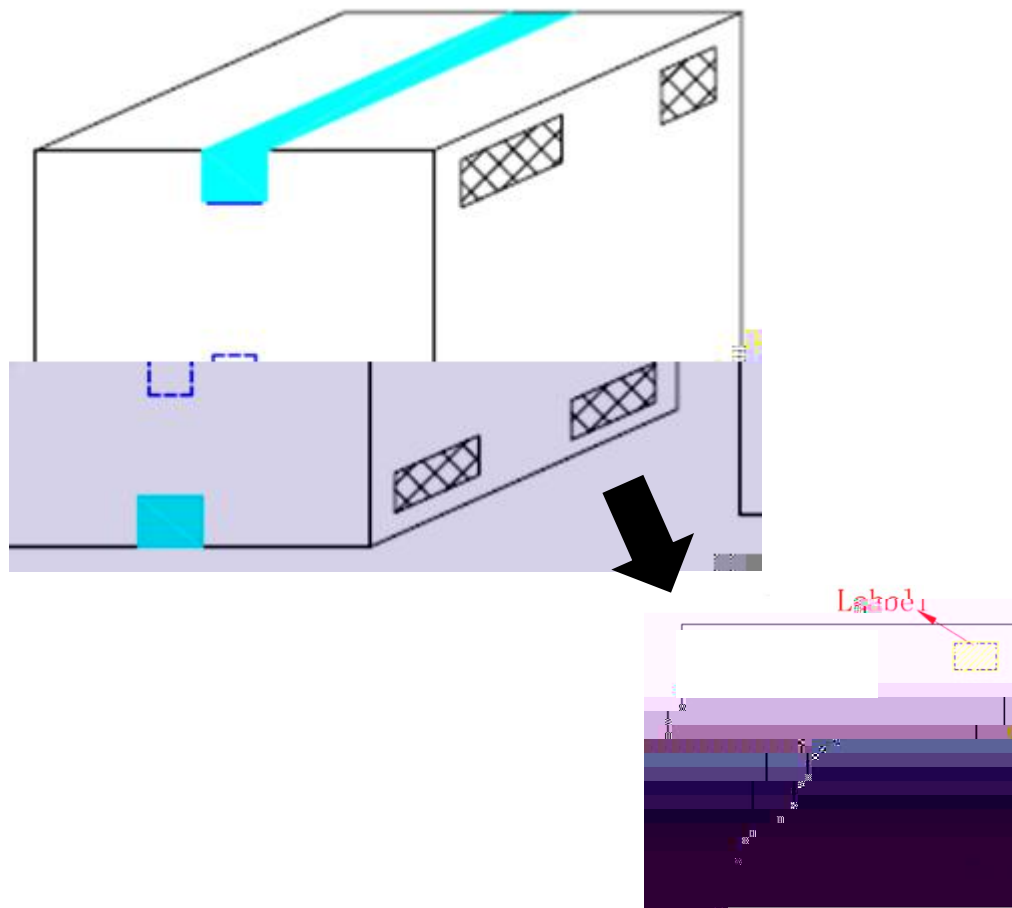

ORDERING AND MARKING INFORMATION

MARKING INFORMATION

JOC : Company Abbr.
3120R : Part Number
V : VDE Option
Y : Fiscal Year
A : Manufacturing Code
WW : Work Week

ORDERING INFORMATION

JOC3120R(Y)(Z)-GV

– Company Abbr.
 3120R – Part Number
 Y – Lead Form Option
 (M/S/SL/SLM/None)
 Z – Tape and Reel Option (T1/T2)
 G – Material Option
 (G: Green, None: Non-Green)
 V – VDE Option (V or None)

LABEL INFORMATION



PACKING QUANTITY

Option	Quantity	Quantity – Inner box	Quantity – Outer box
None	4 Units/Tube		

REFLOW INFORMATION

REFLOW PROFILE

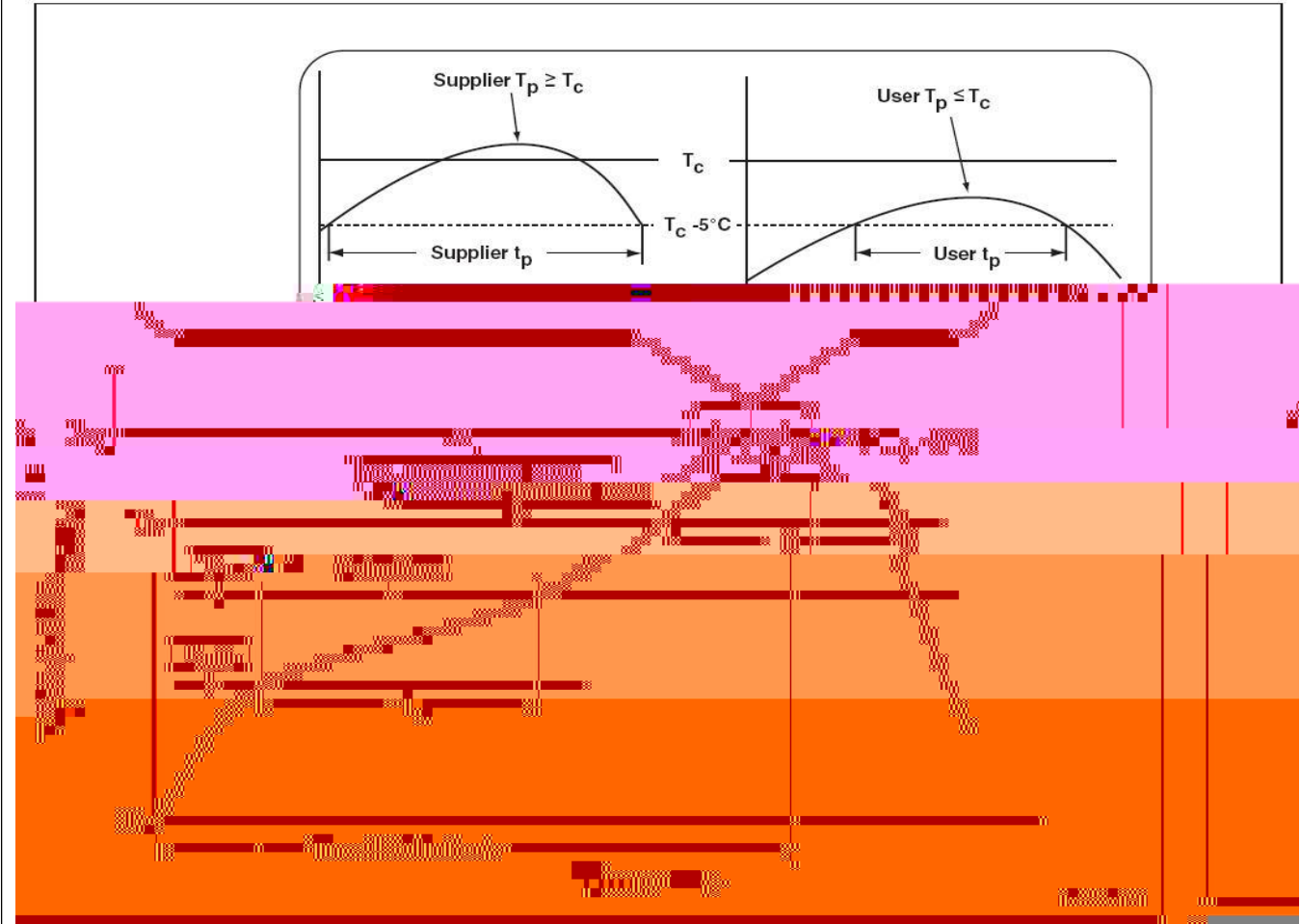

Profile Feature	Sn-Pb Assembly Profile	Pb-Free Assembly Profile
Temperature Min. (T _{min})	100	150°C
Temperature Max. (T _{max})	150	200°C
Time (t _s) from (T _{min} to T _{max})	60-120 seconds	60-120 seconds
Ramp-up Rate (t _L to t _P)	3°C/second max.	3°C/second max.
Liquidous Temperature (TL)	183°C	217°C
Time (t _L) Maintained Above (TL)	60 – 150 seconds	60 – 150 seconds
Peak Body Package Temperature	235°C +0°C / -5°C	260°C +0°C / -5°C
Time (t _P) within 5°C of 260°C	20 seconds	30 seconds
Ramp-down Rate (TP to TL)	6°C/second max	6°C/second max
Time 25°C to Peak Temperature	6 minutes max.	8 minutes max.

DISCLAIMER

- z - , (- , is continually improving the quality, reliability, function and design. - , (- , (reserves the right to make changes without further notices.
- z The characteristic curves shown in this datasheet are representing typical performance which are not guaranteed.
- z - , (- , (makes no warranty, representation or guarantee regarding the suitability of the products for any particular purpose or the continuing production of any product. To the maximum extent permitted by applicable law, - , (- , (disclaims (a) any and all liability arising out of the application or use of any product, (b) any and all liability, including without limitation special, consequential or incidental damages, and (c) any and all implied warranties, including warranties of fitness for particular
- z The products shown in this publication are designed for the general use in electronic applications such as office automation, equipment, communications devices, audio/visual equipment, electrical application and instrumentation purpose, non-infringement and merchantability.
- z This product is not intended to be used for military, aircraft, automotive, medical, life sustaining or lifesaving applications or any other application which can result in human injury or death.
- z Please contact - , (- , sales agent for special application request.
- z Immerge unit's body in solder paste is not recommended.
- z Parameters provided in datasheets may vary in different applications and performance may vary over time. All operating parameters, including typical parameters, must be validated in each customer application by the customer's technical experts. Product specifications do not expand or otherwise modify - , (- , (terms and conditions of purchase, including but not limited to the warranty expressed therein.
- z Discoloration might be occurred on the package surface after soldering, reflow or long-time use. It neither impacts the performance nor reliability.